

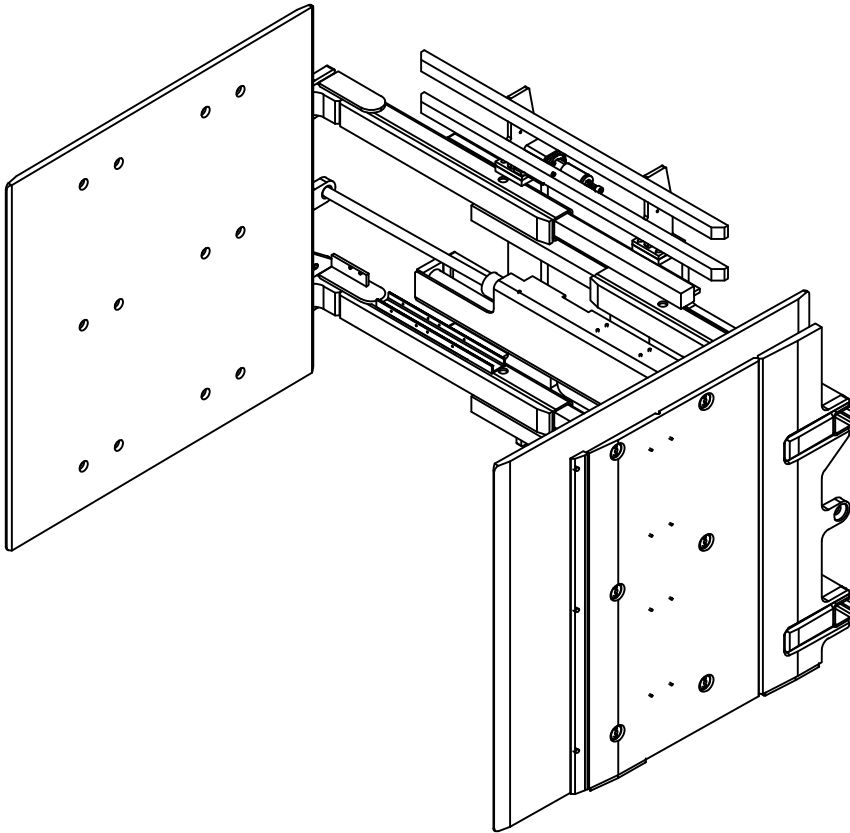

SERVICE MANUAL / PARTS LIST

APPLIANCE CLAMP SOFT TOUCH

MODEL #113784
PATENT NO. 9,630,821
PATENT NO. 10,597,272



CONTENT:

PAGE	
1	Lift Truck Requirements General Installation Procedures General Inspection & Maintenance
2-4	Clamp Assembly
5	Arm Group Assembly
6-8	Floating Pad Assembly
9-11	Hydraulic Assembly
12	Cylinder Assembly
13	Clamp Adjustments
14	Control Valve
15	Clamp Force Control Valve
16	Arm Slide & Shim Replacement
17	Trouble Shooting Guide

Specifications:

Mounting: Class II
Side Shifting: External Side Shifting
Capacity: 2000 lbs at 24"
Pad Size: 48" High x 48" Long
Range: 16.4" - 66.4"
Frame: 43" Wide

R0 - 08/2023

425 Hazel St.
Kelso WA 98626
(800) 248-6079
Fax (360) 578-9934

LIFT TRUCK REQUIREMENTS

CAPACITY

Capacity shown on the clamp's name plate is for the clamp only. The combined truck and clamp capacity is provided by the lift truck manufacturer.

CLAMP HYDRAULICS

Recommended Truck Pressure: 2300 to 2400 PSI (159 to 165 bar).

Hydraulic fluid: petroleum based hydraulic fluid only.

Hydraulic supply group: includes hoses and take-up - one for each function.

Auxiliary valves: 2 function (Side Shift & Clamp) = double auxiliary valve.

Oil Volume Settings:

Side Shift = 3 GPM

Clamp Open/Close = 7 GPM

NOTE: Three Position Force Selector must be disabled.

GENERAL INSTALLATION PROCEDURES

1. Make sure that the attachment centering lug is correctly seated in truck carriage center notch.
2. Clearance between the lower retainers that hold the attachment to the truck lower carriage bar should be as shown below.

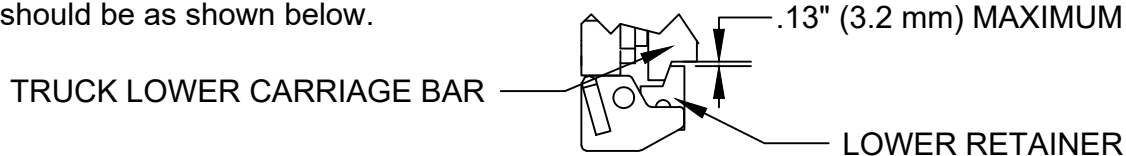

3. Connect hydraulic jumper hoses from the truck's supply group to the attachment's main manifold.
4. Standing clear of the clamp attachment, cycle the attachment in and out several times. Partially filled hydraulic lines may cause erratic movement.

GENERAL INSPECTION AND MAINTENANCE

1. Check all hydraulic fittings, hoses, cylinders and valves for leakages - repair or replace as required.
2. Check bladder system pressure. If out of operating range adjust as required using the LORON hand pump (PN: 112909) and pure propylene glycol antifreeze mixed 1:1 with water. Check clamp force and adjust.

Time Schedule: Check bladder pressure every day and clamp forces every 3 weeks

Bladder System Pressure: 4 - 6 PSI

3. All bolts should be checked and tightened as required.
4. Check lower retainer clearance - see item 2 in the General Installation Procedures above.

CLAMP ASSEMBLY - 1

Drawing Reference: 113712.3

#	QTY	PART #	DESCRIPTION
1	1	113878	Frame Weldment
2	2	111714.9	Cylinder Assembly
3	1	111439.8	Load Backrest
4	6	1C.0820	Bolt
5	8	4E.08	Lock Washer
6	4	111631	Spherical Bearing
7	4	100029.301	O-Ring
8	4	100574.83	Cotter Pin
9	2	111380	Cylinder Rod Washer
10	2	107870.1	Lower Retainer
11	1	113880	Cylinder Guard
12	4	25GN.0612	Bolt
13	4	109528	Nord-Lock Washer
14	2	1C.0828	Bolt
15	2	11G.08136	Bolt
16	2	17D.08	Esna Nut
17	1	100106	Cylinder Assembly
18	1	113028	Hook Weldment
19	6	11G.1040	Bolt
20	6	16E.10	Lockwasher
21	2	108421	Slide II
22	1	113029	Cylinder Anchor Weldment
23	1	113262	Lower Slide
24	1	113150.1	Shim
25	2	25GN.0612	Bolt
26	1	100095.05	Fitting
27	1	100222.1	Restrictor Fitting
28	2	100075.14	Grease Fitting
29	1	108272	Brass Set Screw
30	1	7D.06	Jam Nut
31	2	11G.0808	Bolt
32	2	16E.08	Lockwasher

CLAMP ASSEMBLY - 2

Drawing Reference: 113712.3

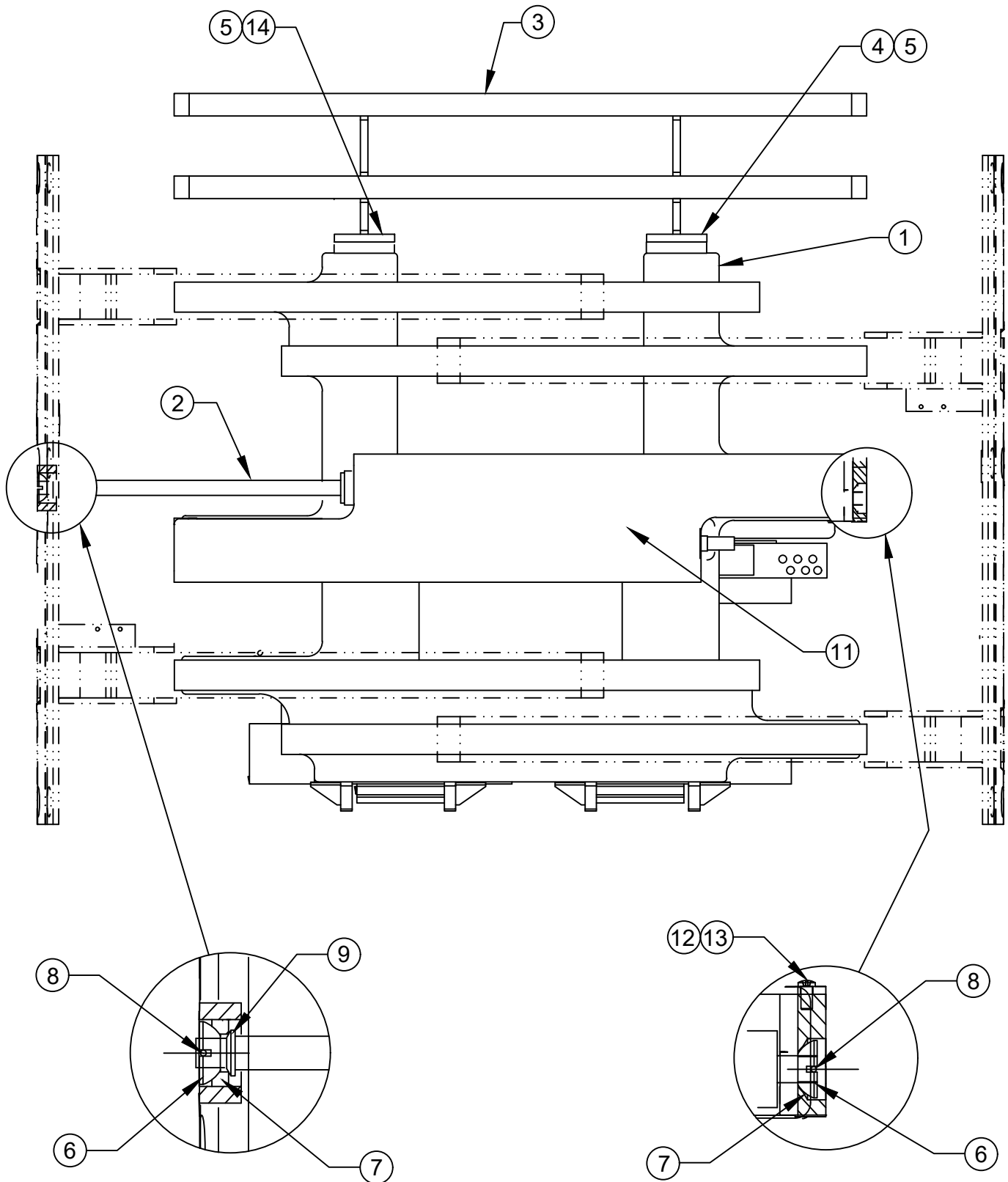

CLAMP ASSEMBLY - 3

Drawing Reference: 113712.3

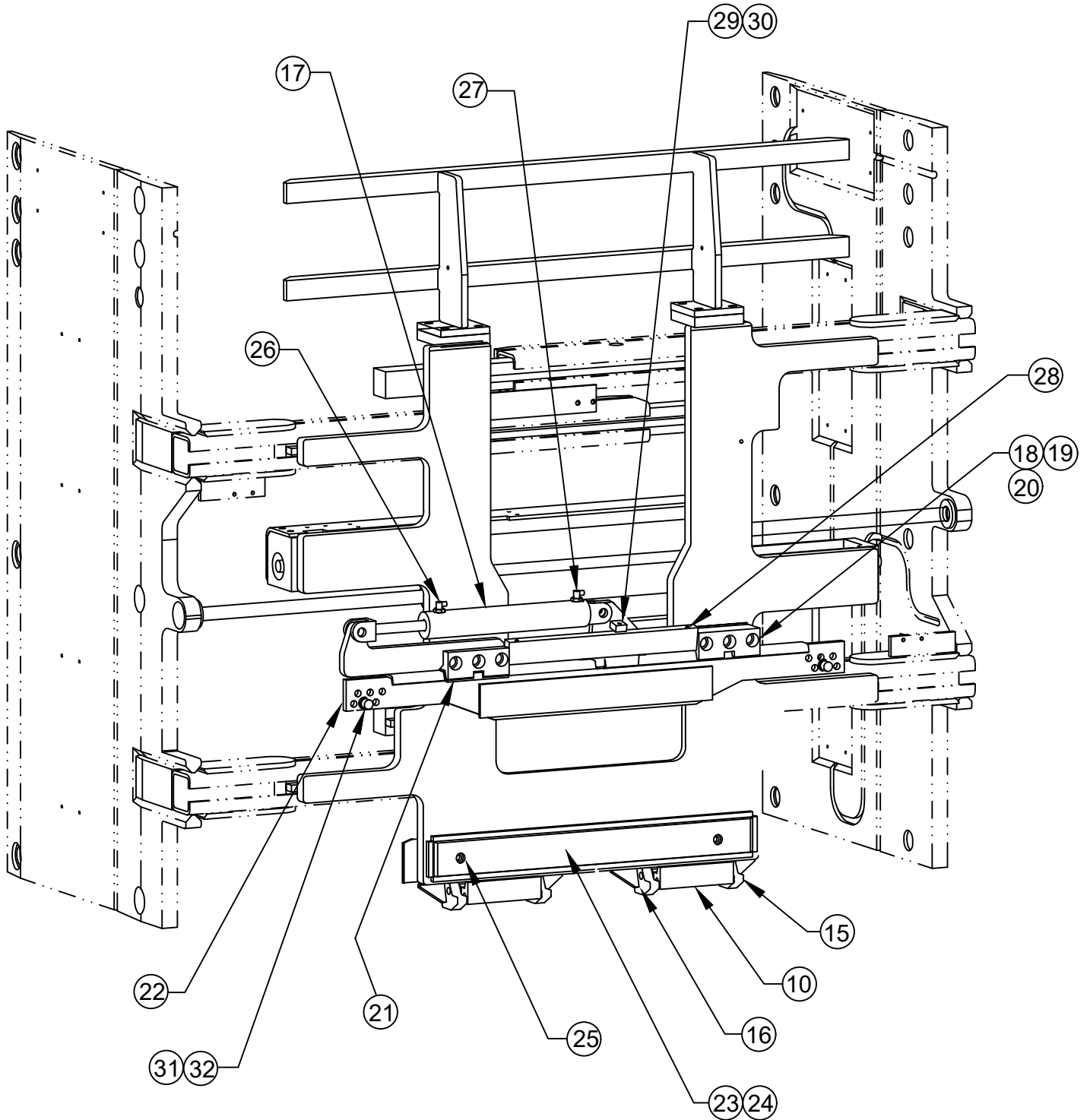

ARM GROUP ASSEMBLY

Drawing Reference: 113700.5

#	QTY	PART #	DESCRIPTION
1	1	113890	Right Hand Arm Weldment
2	1	113891	Left Hand Arm Weldment
3	2	113674	Contact Pad
4	12	111031	Retaining Nut
5	1	113717	Right Hand Tip Plate
6	1	113718	Left Hand Tip Plate
7	12	1C.0820	Bolt
8	6	1C.0812	Bolt
9	18	108088	Spring Washer
10	4	114576.2	Flat Slide
11	8	111621.2	Angle Slide
12	8	109212.5	Shim
13	12	111619	Slide Button

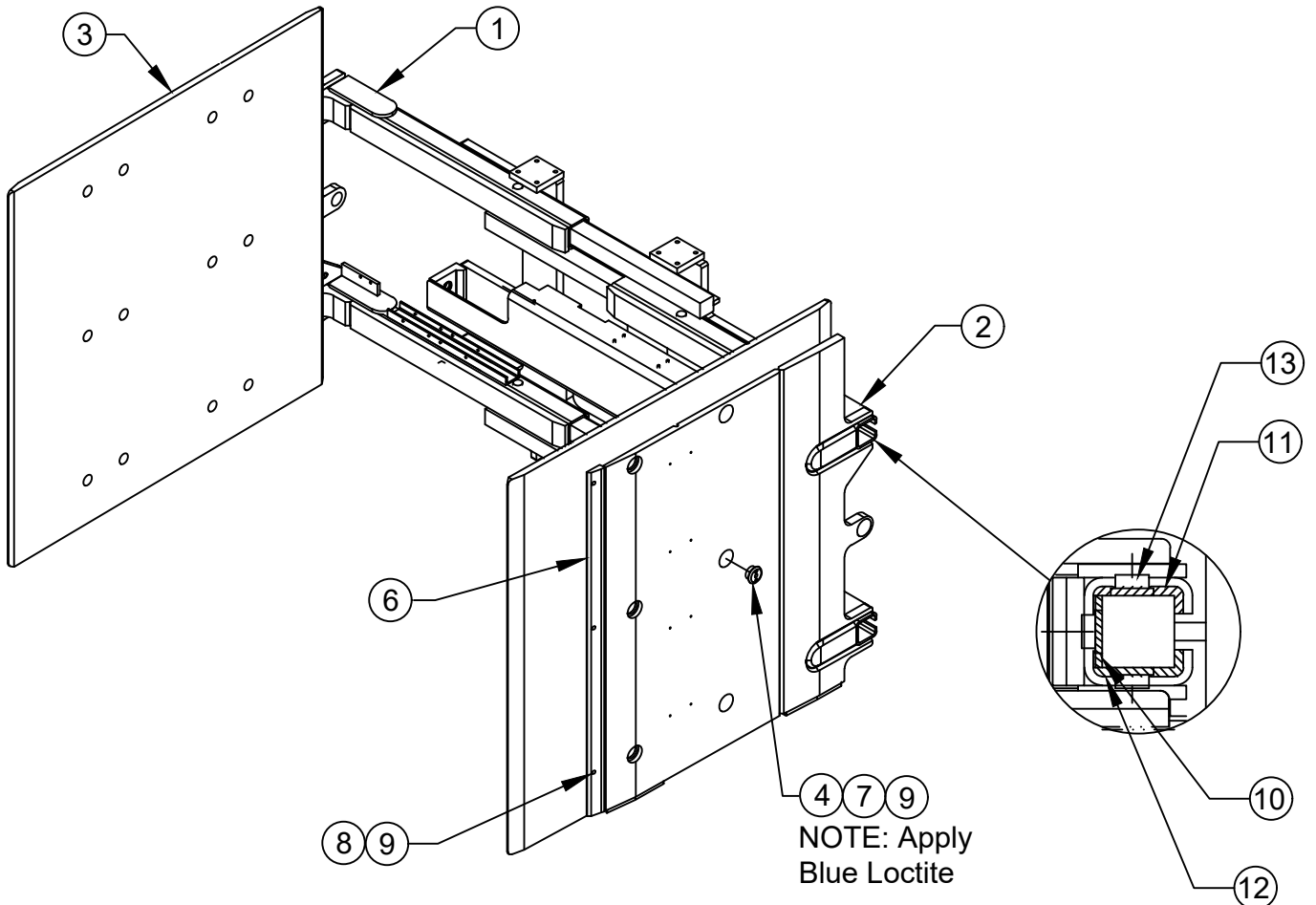

FLOATING PAD ASSEMBLY - 1

Drawing Reference: 113740.3

#	QTY	PART #	DESCRIPTION	#	QTY	PART #	DESCRIPTION
1	3	111350	Air Tank Valve	17	2	113026.0360	Cover Hose
2	9	111295	Hose Clamp	18	2	111290.0087	Hose
3	1	111290.0025	Hose	19	16	9G.0414	Bolt
4	1	111296	Pressure Gauge	20	8	111471	Clamp Bar
5	1	111543.01	90° Elbow Fitting	21	8	109256	Hose Clamp
6	1	111292	Branch Tee	22	8	25GN.0508	Bolt
7	1	111290.0075	Hose	23	4	111128	Hose Guide
8	1	111293	Run Tee	24	12	1C.0512	Bolt
9	1	111290.0057	Hose	25	1	113720	Directional Valve Assy. Ref.
10	1	111290.0165	Hose	26	1	111289	Pipe Elbow
11	1	111290.1170	Hose	27	2	111510	Spring
12	1	111290.0985	Hose	28	16	111878	19 Gauge Wire Tie
13	1	111299	Hose Clip	29	2	113525	Extrusion w/ Holes
14	1	25G.0520	Bolt	30	8	3G.0808	Bolt
15	4	111030	Bladder	31	3	111653	Valve Cap
16	2	111290.0020	Hose	32	1	113970	Wye

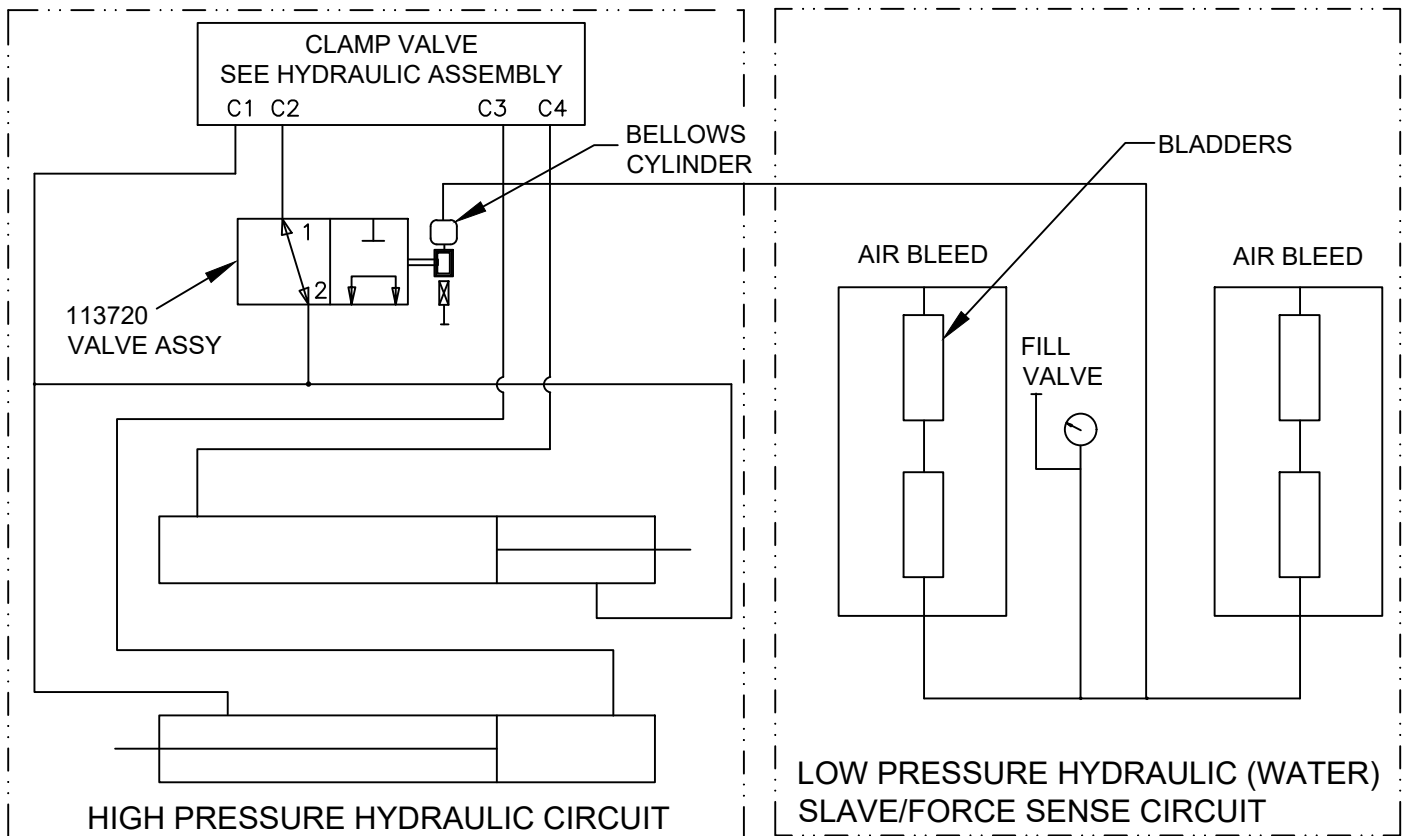

FLOATING PAD ASSEMBLY - 2

Drawing Reference: 113740.3

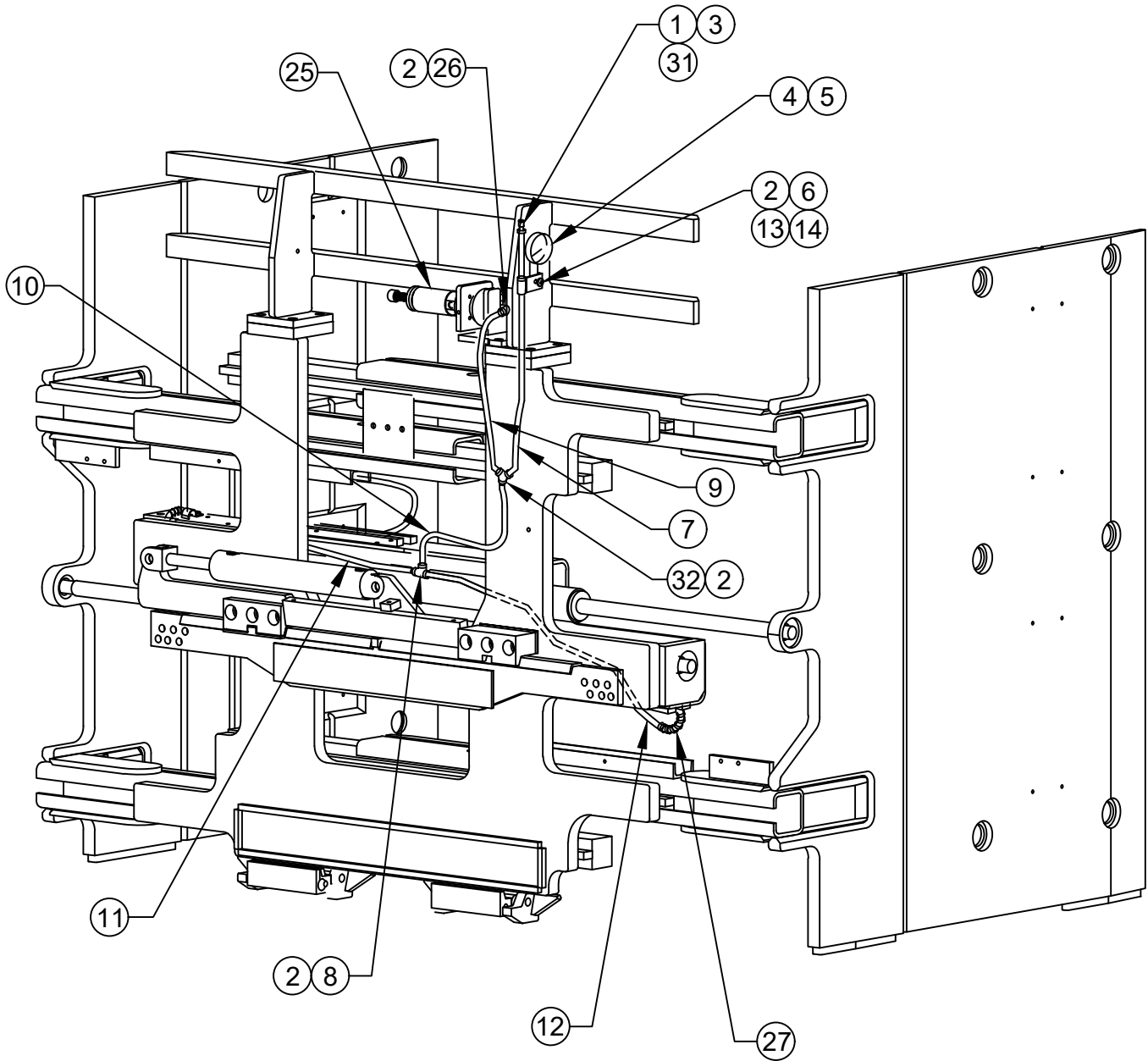

FLOATING PAD ASSEMBLY - 3

Drawing Reference: 113740.3

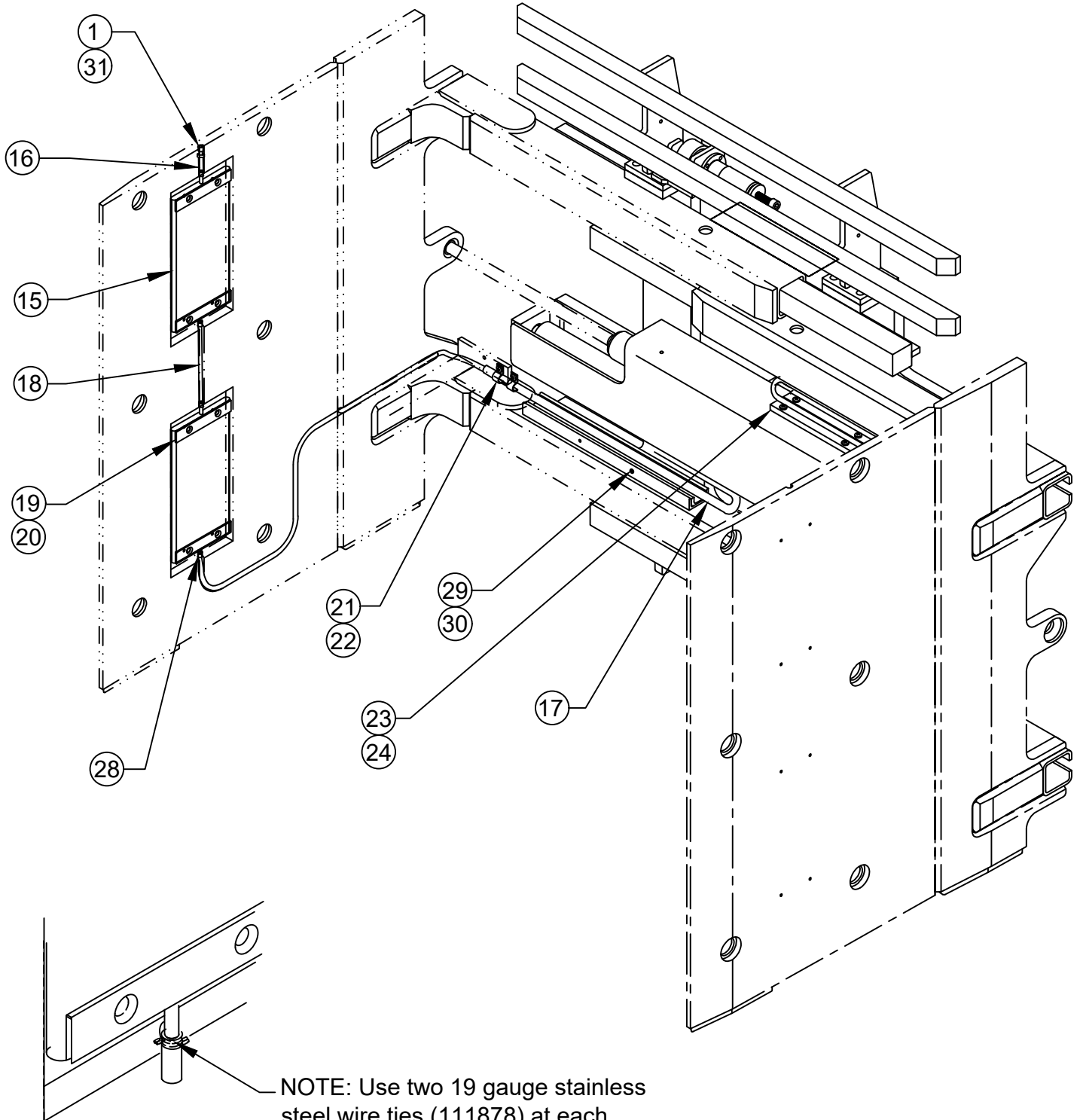

NOTE: Use two 19 gauge stainless steel wire ties (111878) at each bladder connection. Twist to tighten and clip to reduce ends.

HYDRAULIC ASSEMBLY - 1

Drawing Reference: 113892

#	QTY	PART #	DESCRIPTION
1	1	114175	Clamp Valve
2	2	25G.0516	Bolt
3	5	100676.05	Straight Thread Adapter
4	-	-	-
5	1	113720	Directional Valve Assembly
6	1	100227.05	Union Tee Fitting
7	1	100674.0053	Hose (REFERENCE)
8	1	111872.0195	Hose
9	1	102702.0193	Hose
10	1	100678.05	Tee Branch Fitting
11	2	100238.05	45° Swivel Fitting
12	1	100674.0325	Hose
13	1	100674.0230	Hose
14	3	100095.05	90° Elbow Fitting
15	1	102702.0310	Hose
16	1	100674.0165	Hose
17	1	113725	Valve Guard
18	2	25G.0412	Bolt
19	1	100676.03	Straight Fitting
20	1	100238.03	45° Swivel Fitting
21	1	100095.03	90° Fitting
22	1	100440.05	90° Swivel Fitting

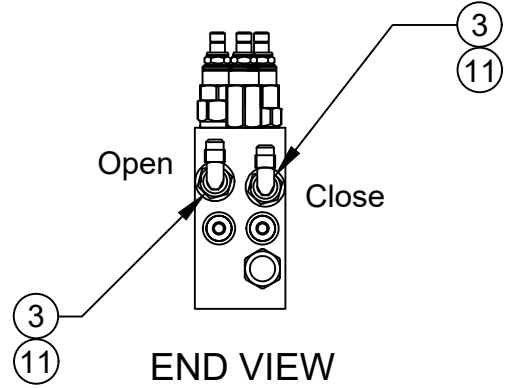

HYDRAULIC ASSEMBLY - 2

Drawing Reference: 113892

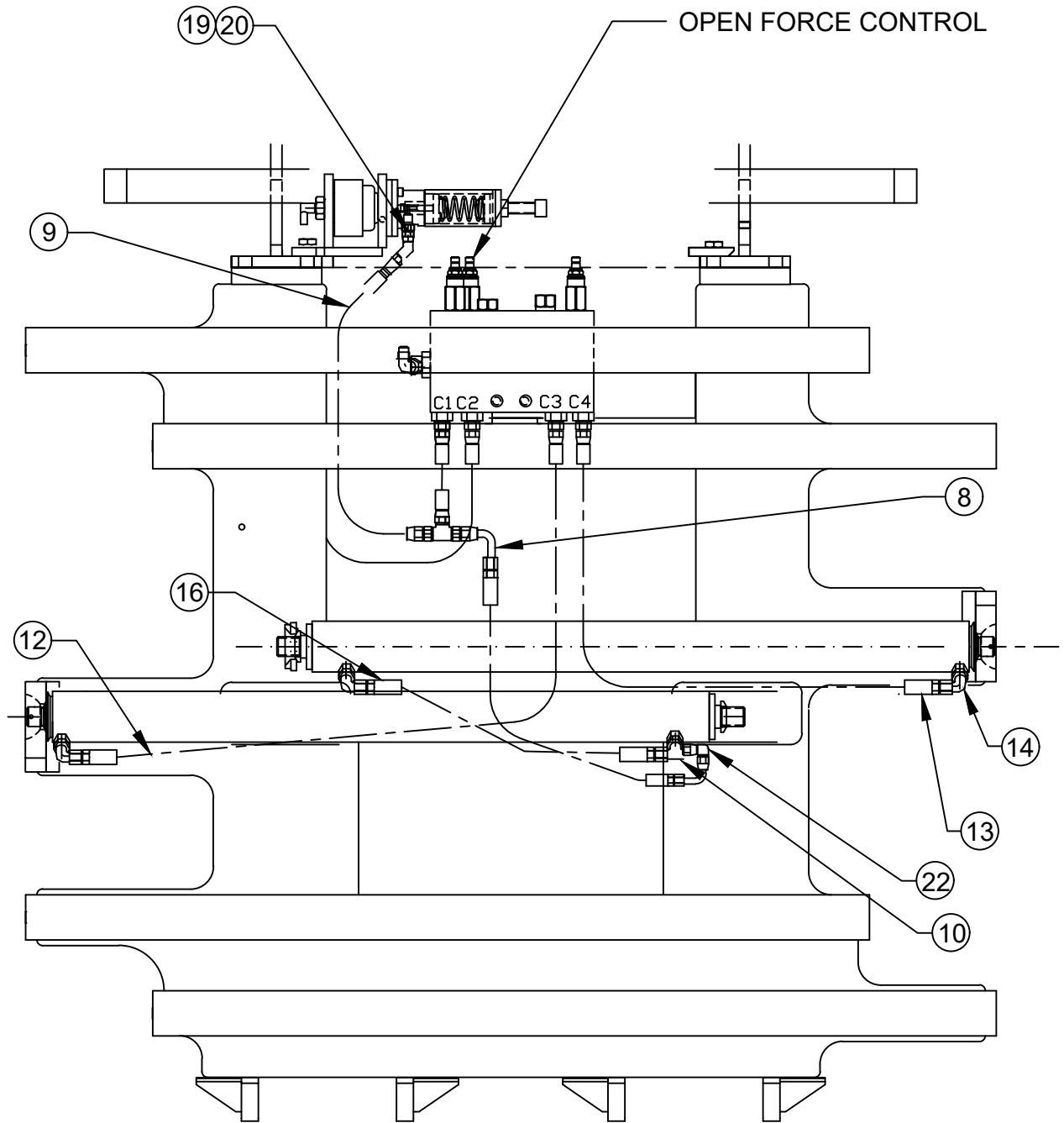

FRONT VIEW

HYDRAULIC ASSEMBLY - 3

Drawing Reference: 113892

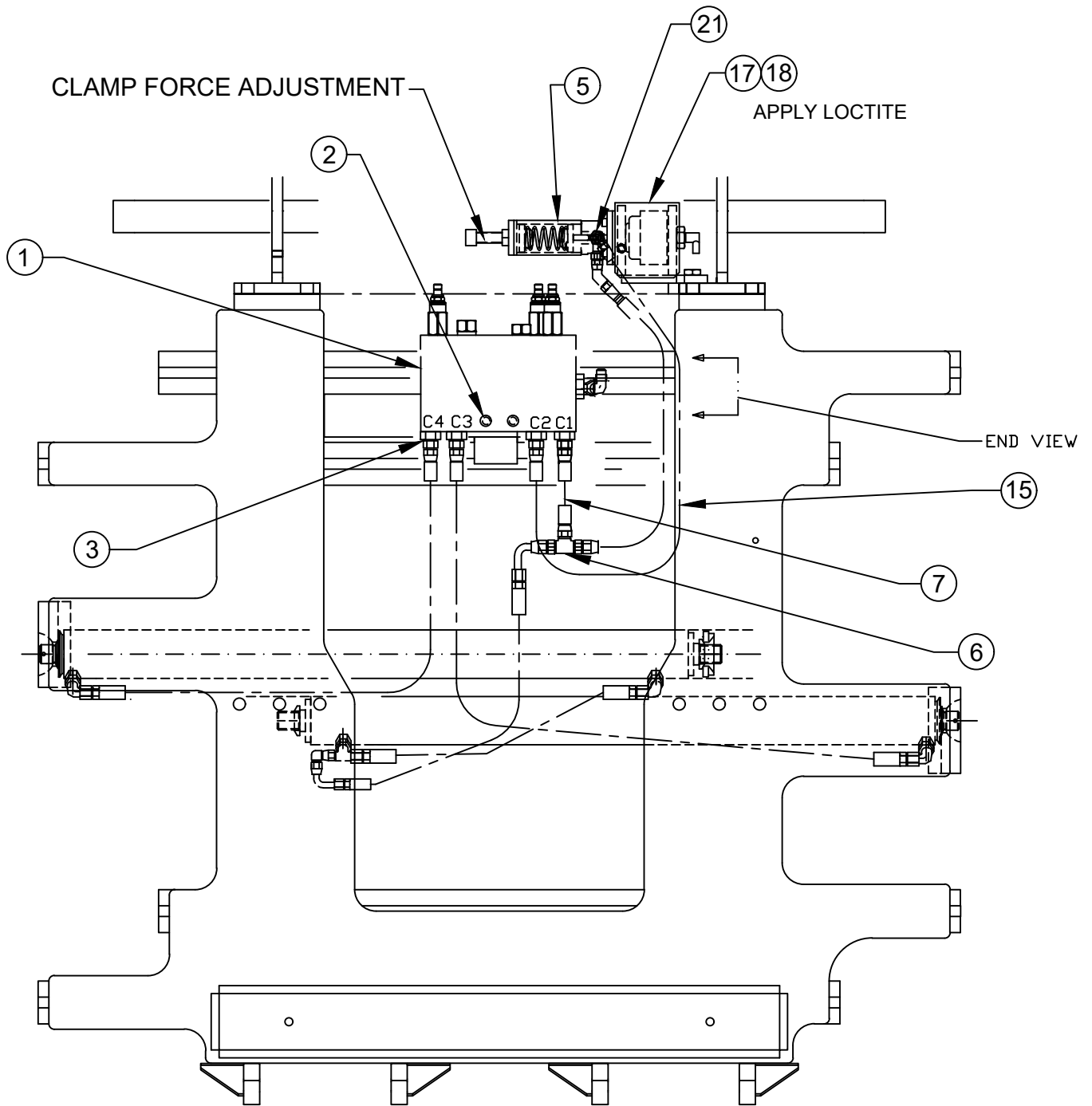

CYLINDER ASSEMBLY

Drawing Reference: 111714.9

Part #	R	E	S	NET STROKE
111714.9	29.81	55.61	25.81	25.81

#	QTY	PART #	DESCRIPTION	8	1	100029.2	O-Ring
1	1	111715.8	Tube Weldment	9	1	100028.2	Back-Up Ring
2	1	111717.8	Rod	10	1	100029.201	O-Ring
3	1	111482	Seal Kit (Items 4-10)	11	1	27D.10	Nut Self Locking
4	1	100032.6	Poly-Pak "B"	12	1	100027.7	Lock Wire
5	1	102099.1	Wear Ring	13	1	111374	Piston
6	1	112905	Rod Seal	14	1	111373	Gland
7	1	102098.5	Rod Wiper	15	1	111380	Washer Cylinder

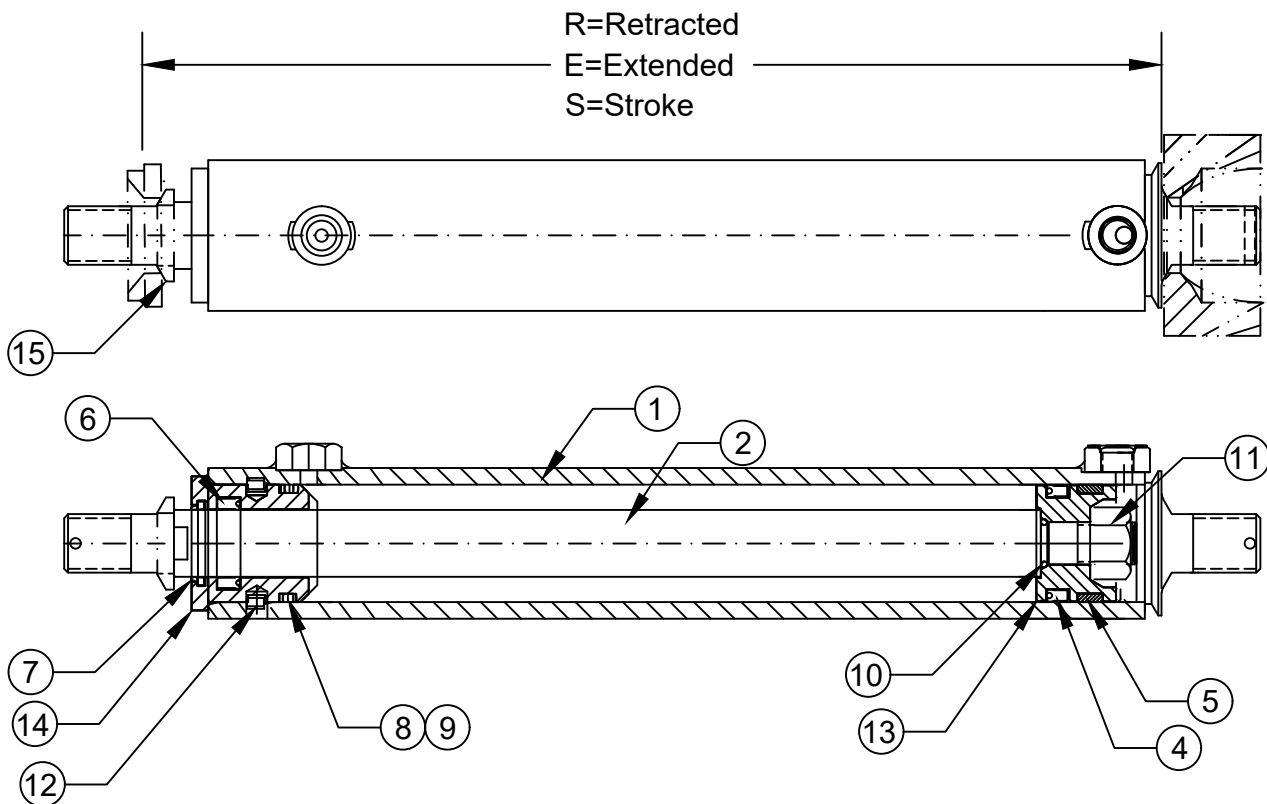

Cylinder Service

- Prior to assembly lubricate seals, cylinder bore and rod with STP.
- Inspect all parts for scratches, nicks and gouges - replace all damaged components.
- Inspect cylinder bore and rod for scoring - replaced if scored.
- Avoid damage to seal grooves - use a dull screwdriver for seal removal.
- Torque piston nut to 100 FT-LBS. (13.8kg-m).

CLAMP ADJUSTMENTS

CLAMP FORCE CHECK/ADJUSTMENT

1. Check water pressure. If out of operating range fill with LORON hand pump # 112909. NOTE: Use pure Propylene Glycol Antifreeze mixed 1 to 1 with water.
2. Check the clamp force. If out of the acceptable force range, adjust with adjustment bolt of the clamp force control valve (see pg 11).

OPEN FORCE CHECK/ADJUSTMENT

Open the arms against a force fixture and adjust for desired maximum force.

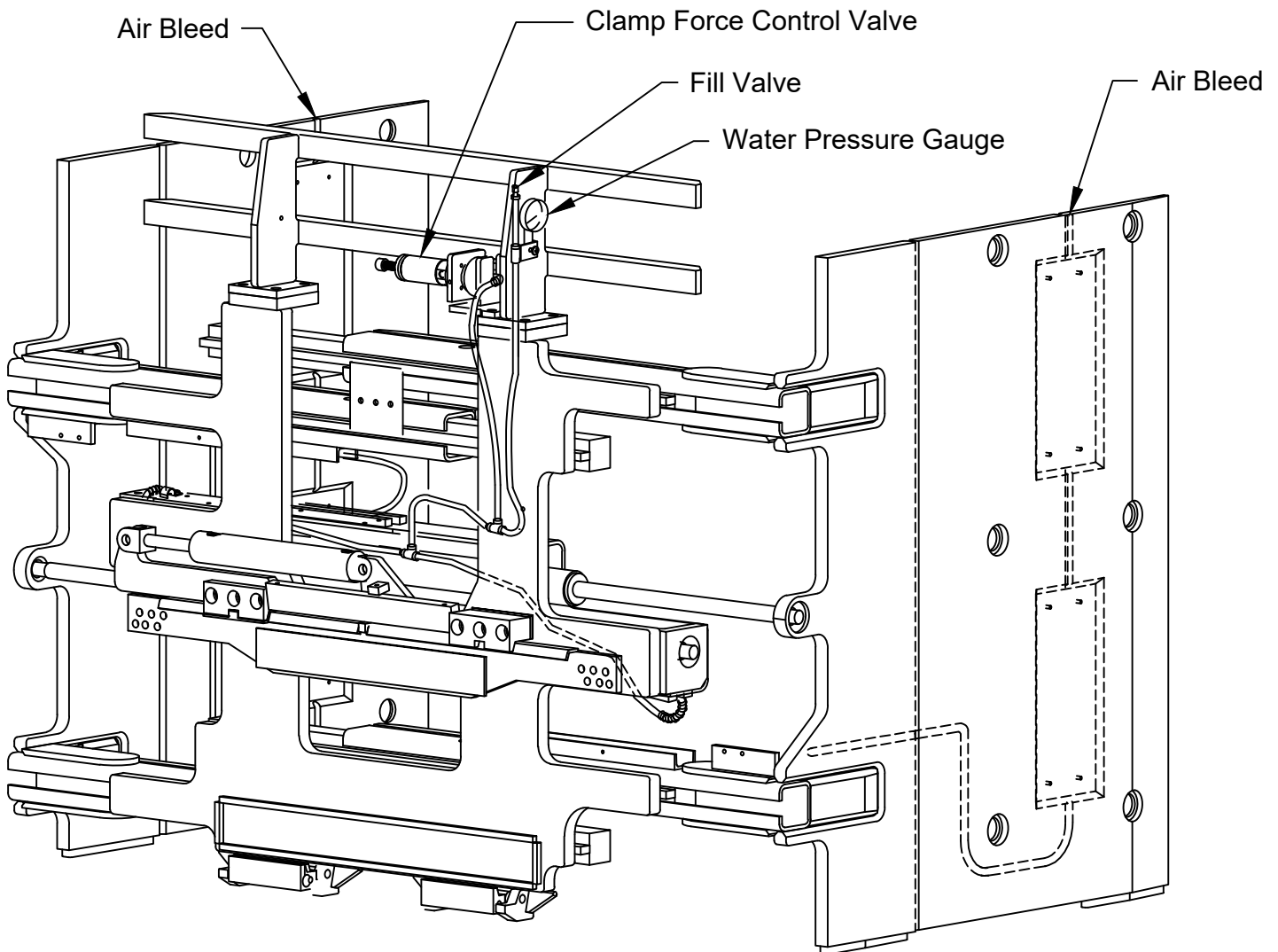

CONTROL VALVE

Drawing Reference: 113773

(A) **113809** Check Valve
 (G) **113983** Check Valve
 Torque 30-35 ft-lb

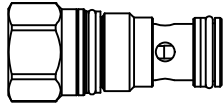

(C) **113806** Flow Divider
 Torque 30-35 ft-lb

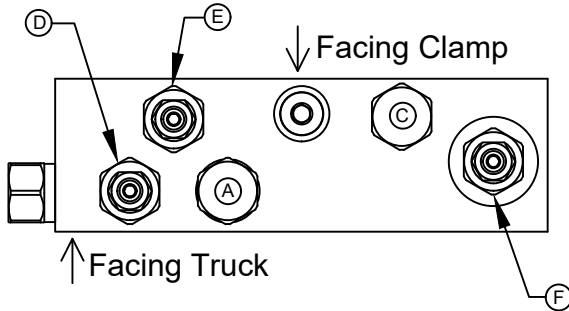
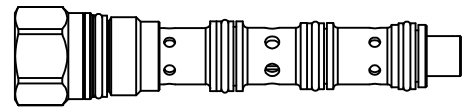

(D) & (E) **113807** Pressure Reducing/Relieving Valve
 Torque 30-35 ft-lb

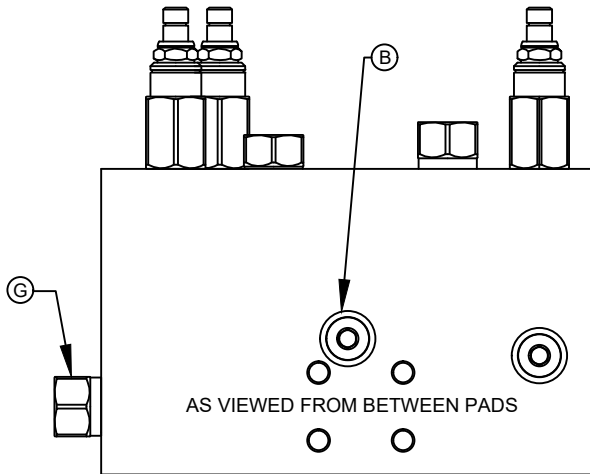
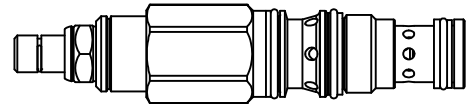

(F) **113810** Bi-Direction Relief Valve
 Torque 28-32 ft-lb

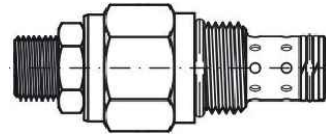

NOTE: Lubricate threads & seals prior to assembly.

ID	QTY	PART #	DESCRIPTION
A	1	113809	Check Valve
B	1	00.030 ORIFICE	Orifice
C	1	113806	Flow Divider
D	1	113807	Pressure Reducing Valve (Close)
E	1	113807	Pressure Reducing Valve (Open)
F	1	113810	Bi-Direction Relief Valve
G	1	113983	Check Valve

HYDRAULIC SCHEMATIC

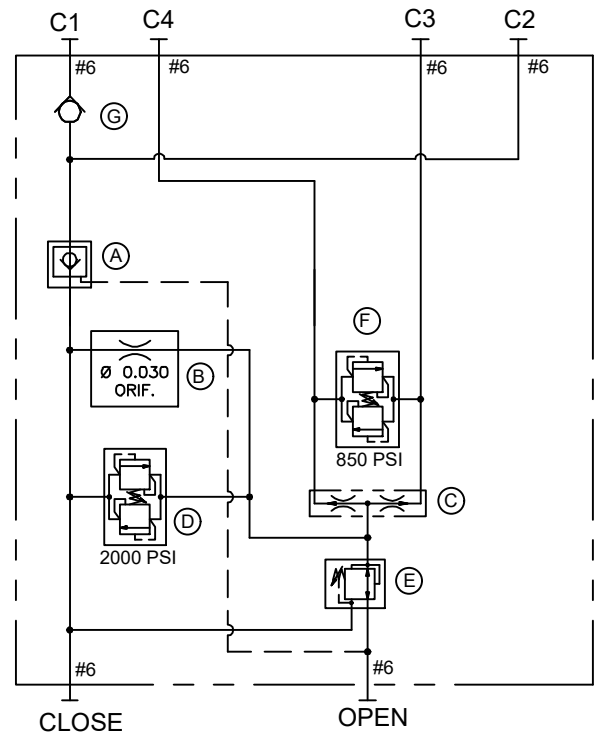

CLAMP FORCE CONTROL VALVE

Drawing Reference: 113720

#	QTY	PART #	DESCRIPTION
1	1	113721	Mounting Plate Weldment
2	1	111091	Air Spring
3	1	THA 7160	Tube
4	1	1C.0514	Bolt
5	1	113680	Spacer
6	4	11G.0414	Bolt
7	1	113779	Control Valve Assembly
8	1	7D.10	Jam Nut
9	1	103488.5	Bearing

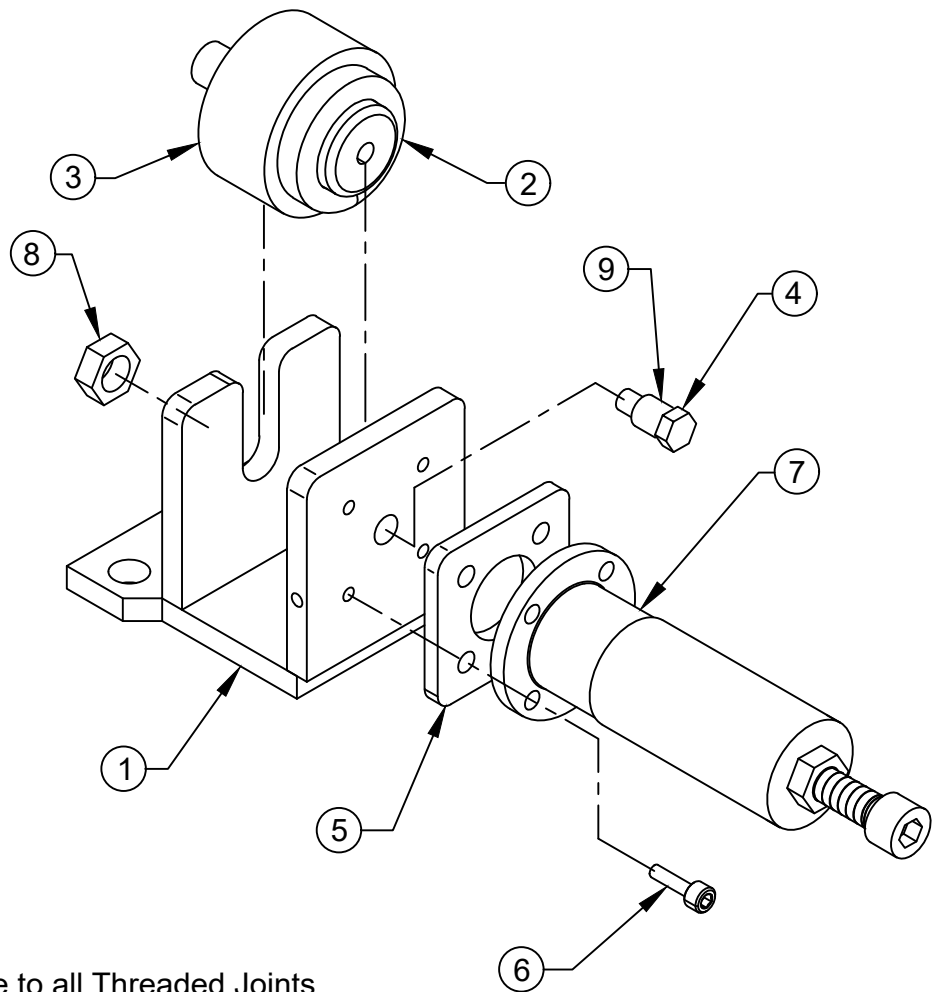

Note: Apply Loctite to all Threaded Joints

ARM SLIDE & SHIM REPLACEMENT

1. To replace the slides, the arms need to be in the fully open position. Release system pressure prior to removing the arms by turning the truck off and working the side shift and clamp function controls several times.
2. Support the arm with an overhead crane or lift truck. Be sure to secure the chain or sling in a manner that prevents the arm from falling out of the chain or sling when hanging free of the clamp.
3. Remove the cotter pin, slotted nut and spherical bearing from the end of the clamp cylinder rod. Keeping hands and feet clear, and carefully slide the clamp arm off of the clamp frame.
4. Inspect slides and slide buttons for wear. Slides may be rotated end-to-end and reused if excessively worn on the outer end only. Extra shims may be used to tighten operating clearance on slightly worn slides. Replace any slides worn to less than 0.15" (3.8mm) thick or any slide that is deeply scored or broken.

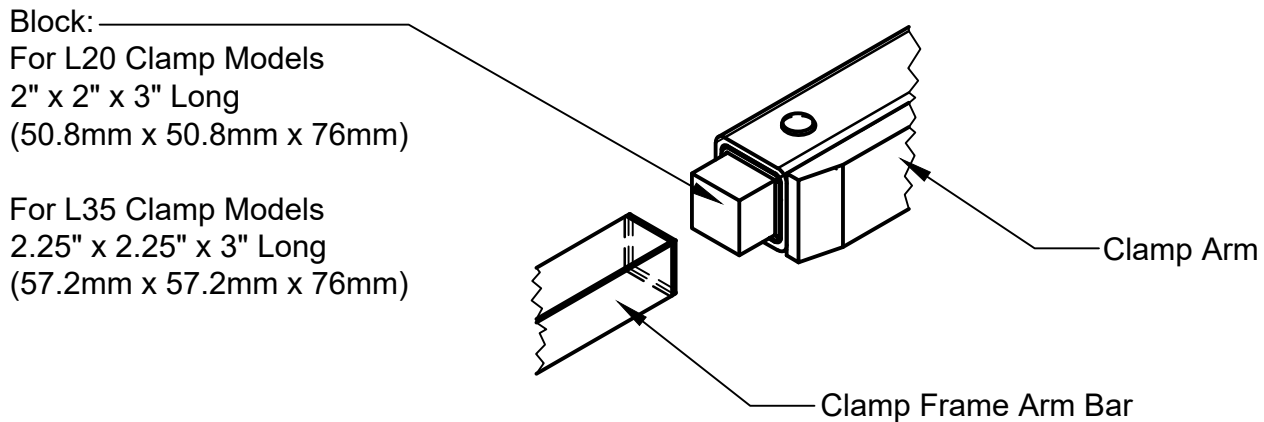

5. To aid in replacing the slides a block may be fashioned of wood or another convenient material to the dimensions shown above. The block is inserted to the end of the arm to hold the slides, shims, and buttons in position while the arm is inserted over the arm bars on the clamp frame. The block is expelled out the opposite end of the arm as the arm is pushed onto the frame. Prior to installing the arm the block may be used to determine the number of shims to place under the slides. Adjust the clearance between the slides and the block to provide approximately .06" (1.5mm) running clearance between the slides and arm when installed.
6. Keeping hands and feet clear, carefully slide the clamp arm onto the clamp frame. Be sure the arm moves freely without excessive binding. If the arm is too loose or too tight add or remove shims as required.
7. Install the spherical bearing, slotted nut and cotter pin onto the end of the clamp cylinder rod. Be sure to leave .03"-.06" (.7mm to 1.5mm) clearance to allow the cylinder to "float" on its mountings.

TROUBLE SHOOTING GUIDE

LOADS SLIPPING OR DROPPING

POSSIBLE CAUSES

SOLUTION

- | | |
|--|--|
| 1. Clamp force set too low. | 1. Adjust clamp force. |
| 2. Internal leakage in cylinder. | 2. Replace cylinder seals. If tube, pistons or rod is scored replace with new parts. |
| 3. Load too heavy for the clamp capacity. | 3. Consult factory. |
| 4. Load may not be stacked correctly or may need to be unitized. | 4. Restack or unitize load (shrink wrap). |
| 5. Bent arms or contact pads. | 5. Consult factory. |
| 6. Damaged / leaking hydraulic hose | 6. Replace damaged hose. |

CRUSHING LOADS

POSSIBLE CAUSES

SOLUTION

- | | |
|--------------------------------|--------------------------------|
| 1. Clamp force set too high. | 1. Adjust clamp force. |
| 2. Bent arms or contact pads. | 2. Consult factory. |
| 3. Leak in the bladder system. | 3. Check for leaks and repair. |

ARM CHATTERING OR ERRATIC MOVEMENT

POSSIBLE CAUSES

SOLUTION

- | | |
|---|--|
| 1. Bent clamp arms. | 1. Consult factory. |
| 2. Nylon slides sticking.
Note: Sticking slides can cause inconsistent force measurements. | 2. Clean slides if necessary, the slides are self lubricating. |
| 3. Nylon slides worn, broken or missing. | 3. Replace damaged slides, shims, and retaining buttons. |