

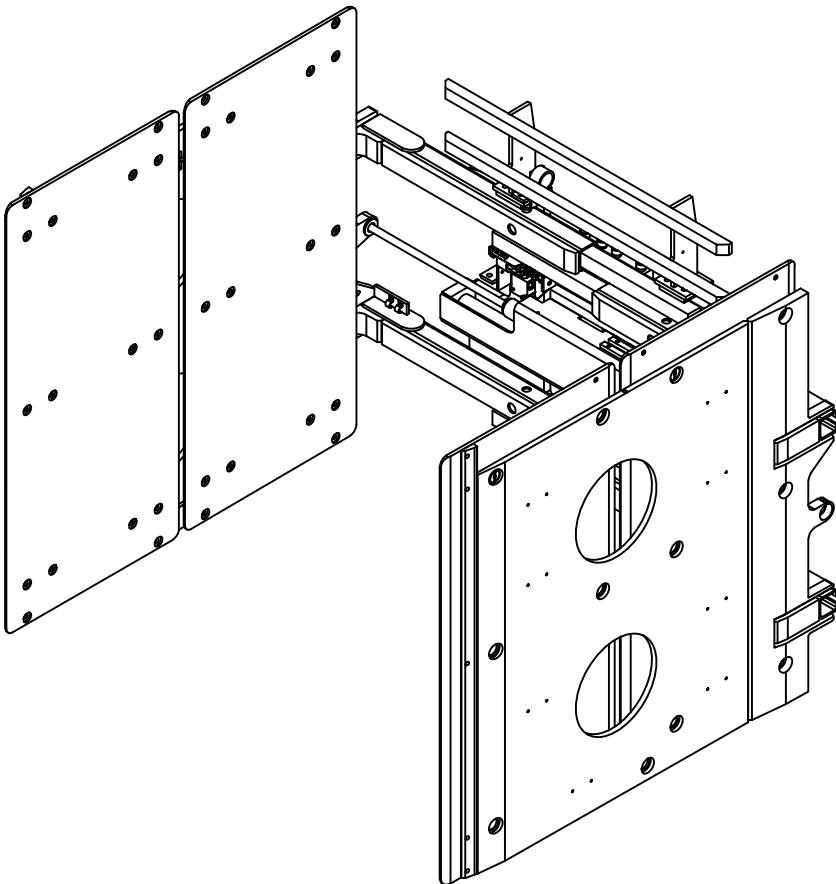

# SERVICE MANUAL / PARTS LIST

## APPLIANCE CLAMP SOFT TOUCH

MODEL #113208  
PATENT NO. 9,630,821  
PATENT NO. 10,597,272



## CONTENT:

### PAGE

1	Lift Truck Requirements General Installation Procedures General Inspection & Maintenance
2-4	Clamp Assembly
5	Arm Group Assembly
6-9	Floating Pad Assembly
10-12	Hydraulic Assembly
13	Cylinder Assembly
14	Clamp Adjustments
15	Control Valve
16	Clamp Force Control Valve
17	Arm Slide & Shim Replacement
18	Trouble Shooting Guide

### Specifications:

Mounting: Class II  
Side Shifting: External Side Shifting  
Capacity: 1600 lbs at 24"  
Pad Size: 48" High x 48" Long  
Range: 22.0" - 82.0"  
Frame: 46" Wide

425 Hazel St.  
Kelso WA 98626  
(800) 248-6079  
Fax (360) 578-9934

---

---

# LIFT TRUCK REQUIREMENTS

---

Capacity shown on the clamp's name plate is for the clamp only. The combined truck and clamp capacity is provided by the lift truck manufacturer.

**Recommended Truck Pressure:** 2300 to 2400 PSI (159 to 165 bar).

**Hydraulic fluid:** petroleum based hydraulic fluid only.

**Hydraulic supply group:** includes hoses and take-up - one for each function.

**Auxiliary valves:** 2 function (Side Shift & Clamp) = double auxiliary valve.

**Oil Volume Settings:**

Side Shift = 3 GPM

Clamp Open/Close = 7 GPM

**NOTE:** Three Position Force Selector must be disabled.

---

---

## GENERAL INSTALLATION PROCEDURES

---

1. Make sure that the attachment centering lug is correctly seated in truck carriage center notch.
2. Clearance between the lower retainers that hold the attachment to the truck lower carriage bar should be as shown below.

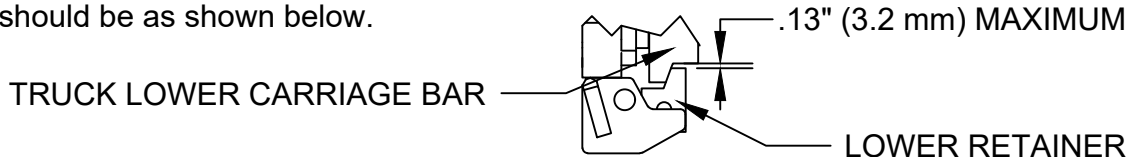

3. Connect hydraulic jumper hoses from the truck's supply group to the attachment's main manifold.
4. Standing clear of the clamp attachment, cycle the attachment in and out several times. Partially filled hydraulic lines may cause erratic movement.

---

---

## GENERAL INSPECTION AND MAINTENANCE

---

1. Check all hydraulic fittings, hoses, cylinders and valves for leakages - repair or replace as required.
2. Check bladder system pressure. If out of operating range adjust as required using the LORON hand pump (PN: 112909) and pure propylene glycol antifreeze mixed 1:1 with water. Check clamp force and adjust.

Time Schedule: Check bladder pressure every day and clamp forces every 3 weeks

Bladder System Pressure: 4 - 6 PSI

3. All bolts should be checked and tightened as required.
4. Check lower retainer clearance - see item 2 in the General Installation Procedures above.

---

---

# CLAMP ASSEMBLY-1

---

Drawing reference 113263.1

#	QTY	PART #	DESCRIPTION
1	1	112878	Frame Weldment
2	2	111372.3	Cylinder Assembly
3	1	111652.2	Load Backrest
4	8	1C.0820	Bolt
5	8	4E.08	Lock Washer
6	4	110731	Spherical Bearing
7	4	110730	Spherical Seat
8	4	100574.83	Cotter Pin
9	2	111380	Cylinder Rod Washer
10	2	107870.1	Lower Retainer
11	2	11G.08136	Bolt
12	2	17D.08	Nut Nylock
13	1	111059	Cylinder Guard
14	4	25GN.0612	Bolt
15	4	109528	Nord-Lock Washer
16	4	100029.314	O-Ring
17	1	100106	Cylinder Assembly
18	1	113028	Hook Weldment
19	6	11G.1040	Bolt
20	6	16E.10	Lock Washer
21	2	108421	Slide II
22	1	113029	Cylinder Anchor Weldment
23	1	113264	Lower Slide
24	1	112882.1	Shim
25	2	25GN.0612	Bolt
26	1	100095.05	Fitting
27	1	100222.1	Restrictor Fitting
28	2	100075.14	Grease Fittings
29	1	108272	Brass Set Screw
30	1	7D.06	Jam Nut
31	2	11G.0808	Bolt
32	2	16E.08	Lock Washer

# CLAMP ASSEMBLY-2

Drawing reference 113263.1

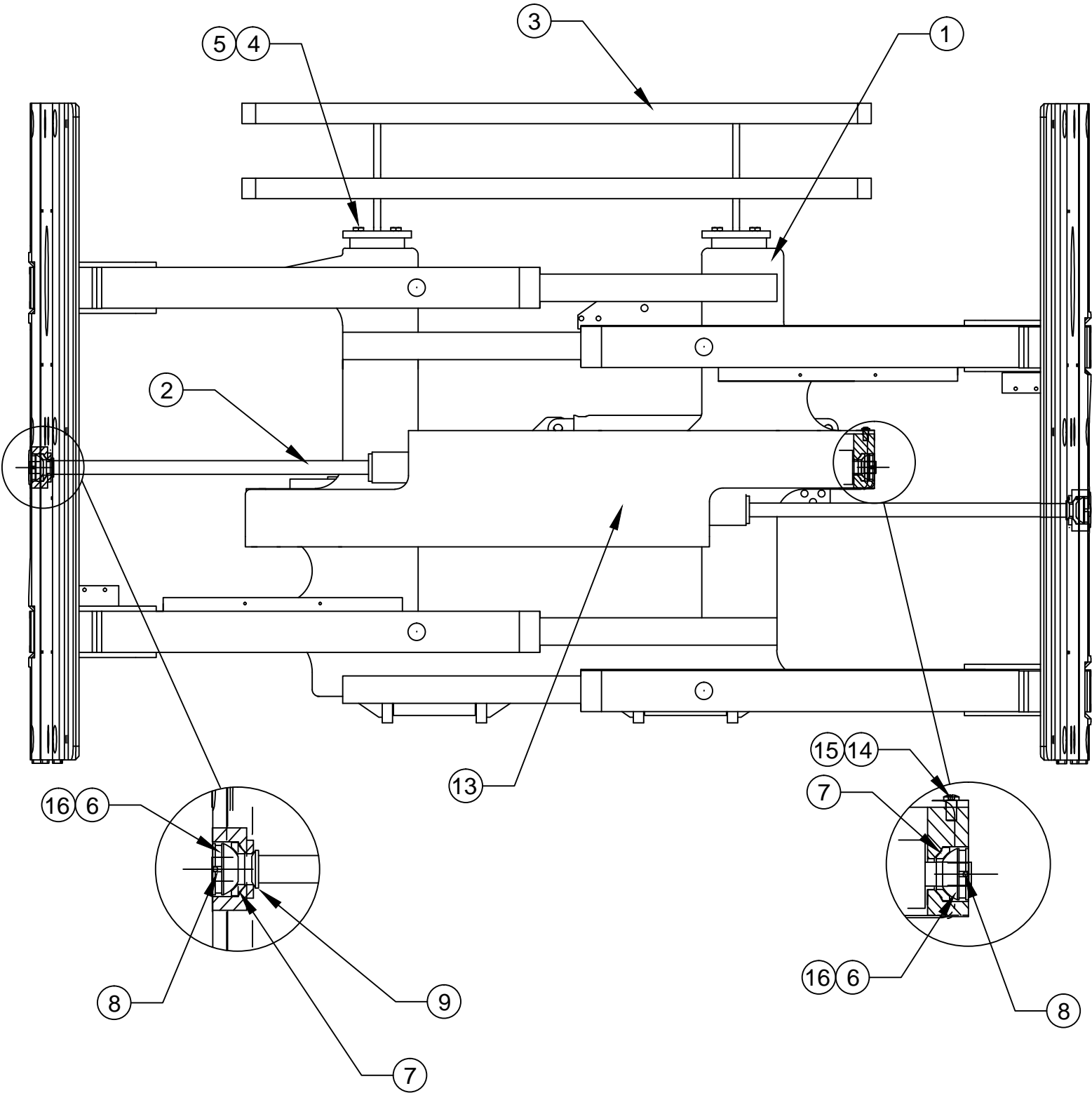

# CLAMP ASSEMBLY-3

Drawing reference 113263.1

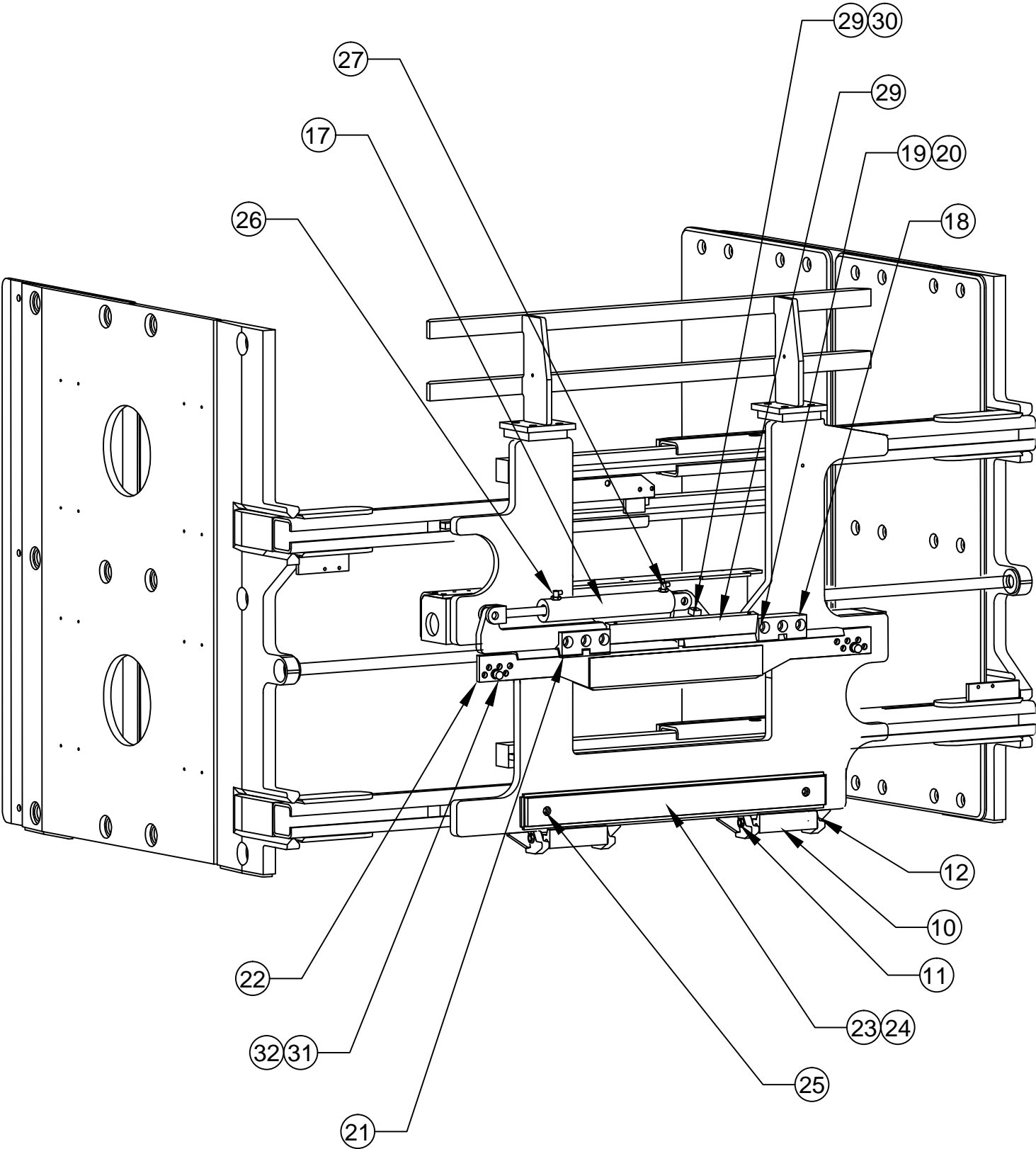

# ARM GROUP ASSEMBLY

Drawing reference 111582.2

#	QTY	PART #	DESCRIPTION
1	1	112860	Right Hand Arm Weldment
2	1	112861	Left Hand Arm Weldment
3	4	112862	Contact Pad
4	24	111031	Retaining Nut
5	1	112871	Left Hand Tip Plate
6	1	112871	Right Hand Tip Plate
7	24	1C.0820	Bolt
8	6	1C.0812	Bolt
9	30	108088	Spring Washer
10	4	111622.1	Flat Slide
11	8	111621.1	Angle Slide
12	12	109212.4	Shim
13	12	111619	Slide Button

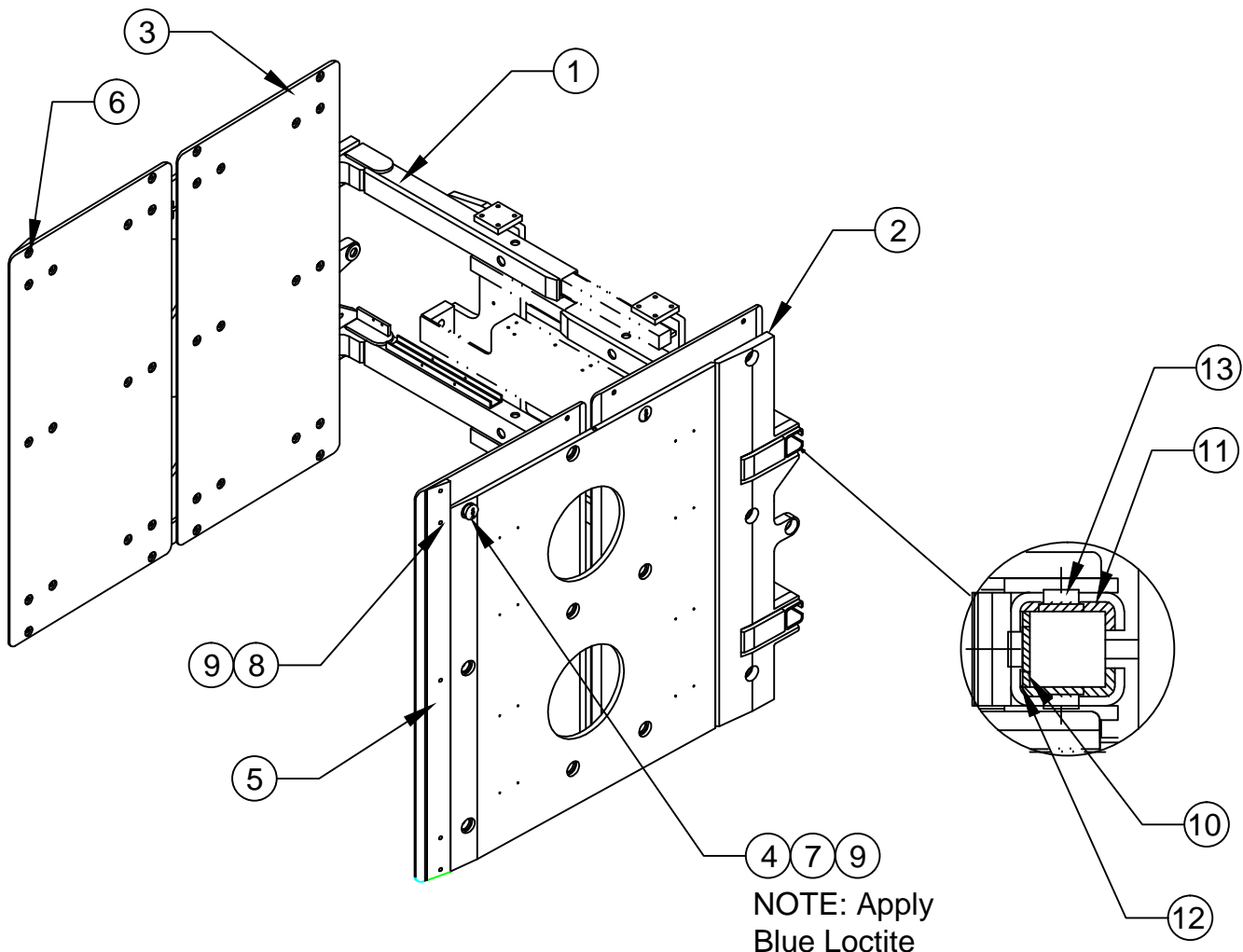

# FLOATING PAD ASSEMBLY-1

Drawing reference 112875.1

#	QTY	PART #	DESCRIPTION	18	2	111290.0250	Hose
1	3	111350	Air Tank Valve	19	8	111030	Bladder
2	12	111295	Hose Clamp	20	32	9G.0412	Bolt
3	1	111290.0025	Hose	21	16	111471	Clamp Bar
4	1	111296	Pressure Gauge	22	8	109256	Hose Clamp
5	1	111543.01	90° Elbow Fitting	23	8	25G.0508	Bolt
6	1	111292	Branch Tee	24	2	113026.0360	Cover Hose
7	1	111290.0178	Hose	25	4	111128	Hose Guide
8	4	111293	Run Tee	26	12	25G.0512	Bolt
9	1	111290.0155	Hose	27	1	111289	Pipe Elbow
10	1	111290.0175	Hose	28	2	111654	Plug
11	1	111290.0805	Hose	29	2	111510	Spring
12	1	111290.0930	Hose	30	16	111878	19 Gauge Stainless Wire Tie
13	1	111299	Hose Clip	31	3	111653	Valve Cap
14	1	25G.0520	Bolt	32	2	111290.0118	Hose
15	2	111290.0027	Hose	33	1	111085	Direction Valve Assembly Ref.
16	2	111290.0127	Hose	34	2	113416	Hose Extrusion w/Holes
17	2	111290.0085	Hose	35	8	3G.0808	Bolt

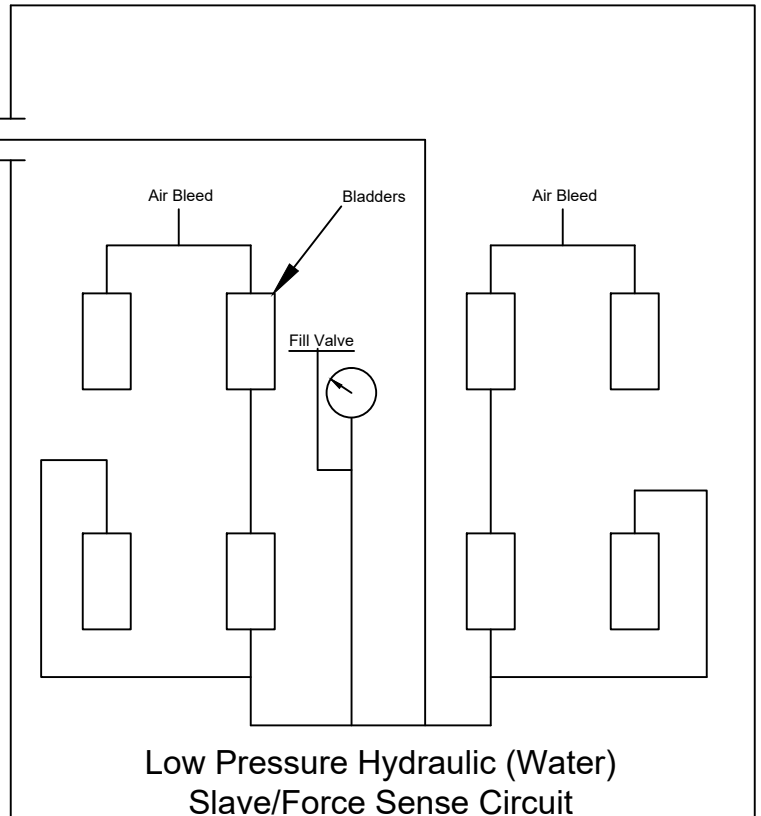
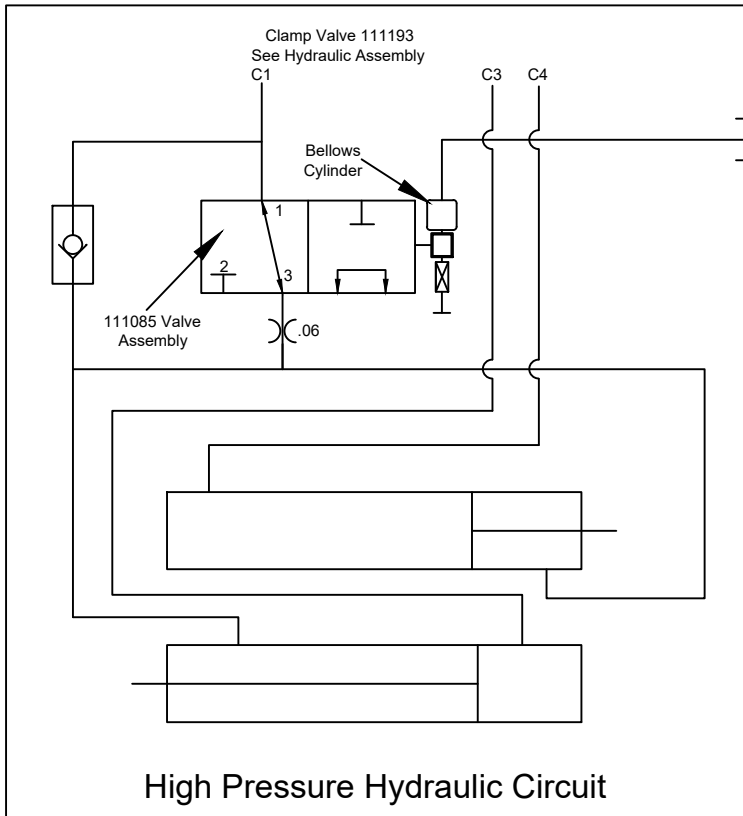

# FLOATING PAD ASSEMBLY-2

Drawing reference 112875.1

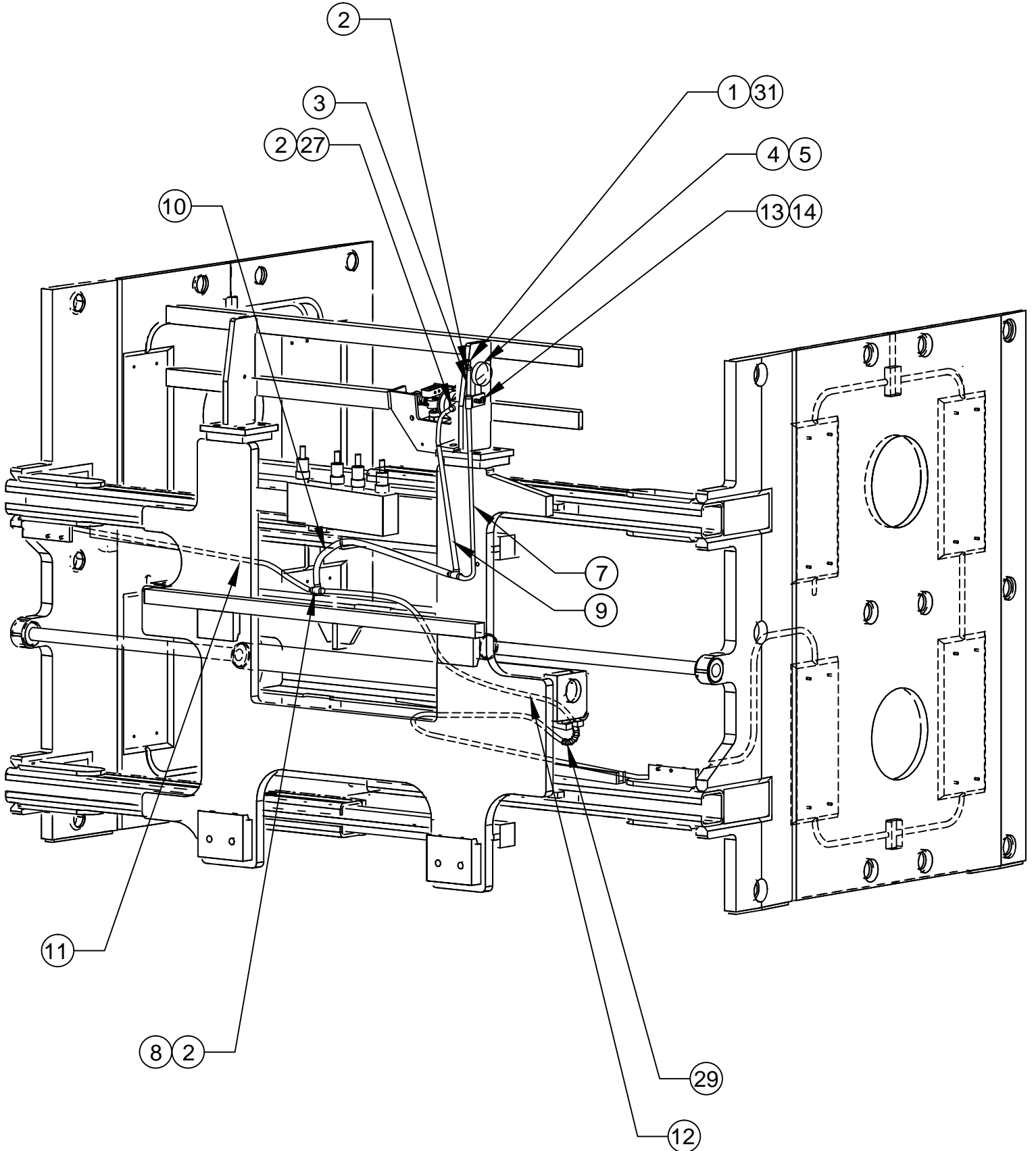



# FLOATING PAD ASSEMBLY-3

Drawing reference 112875.1

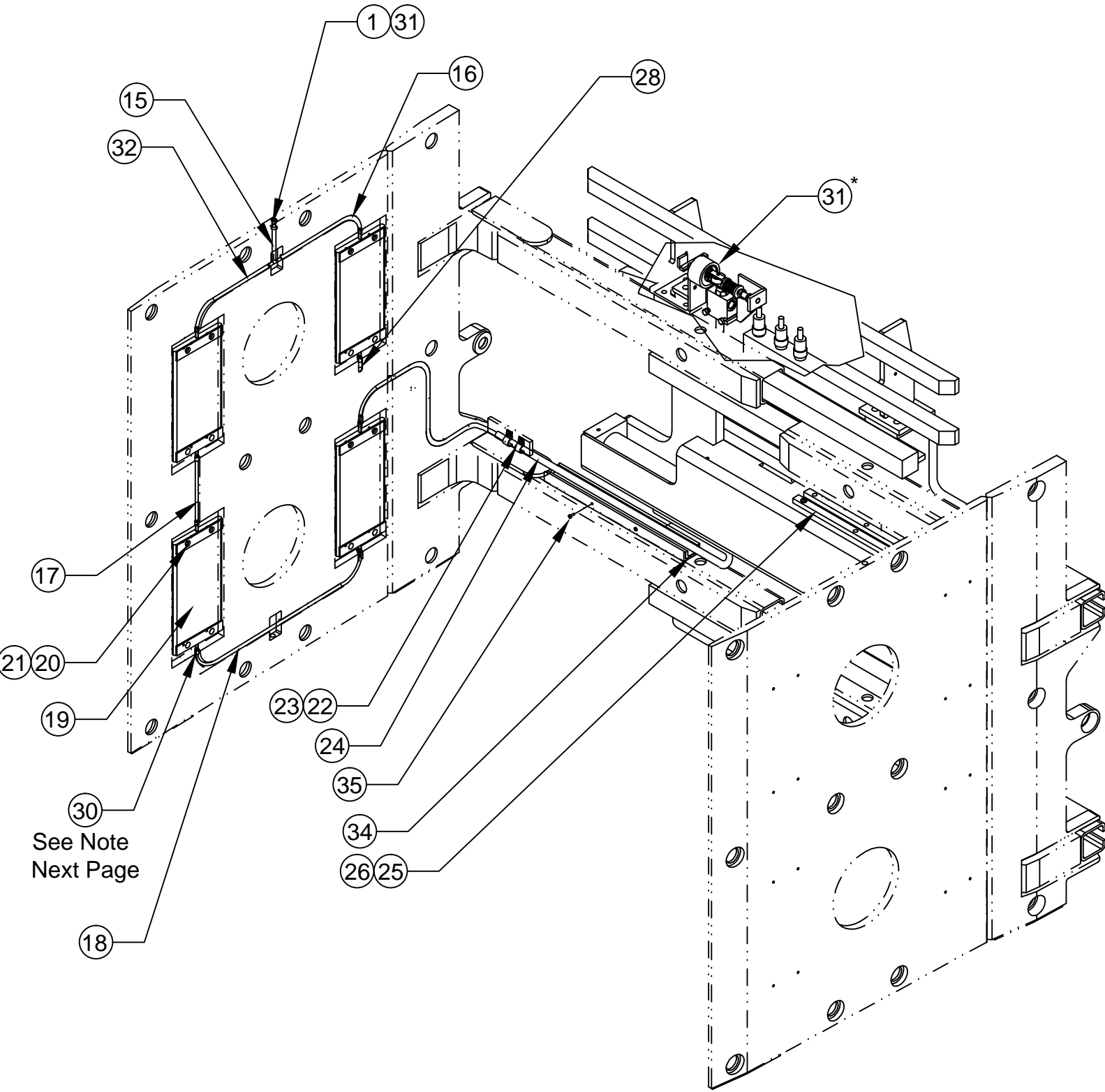

See Note  
Next Page

# FLOATING PAD ASSEMBLY-4

Drawing reference 112875.1

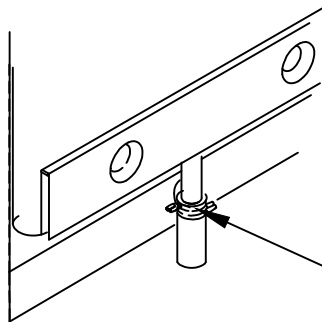
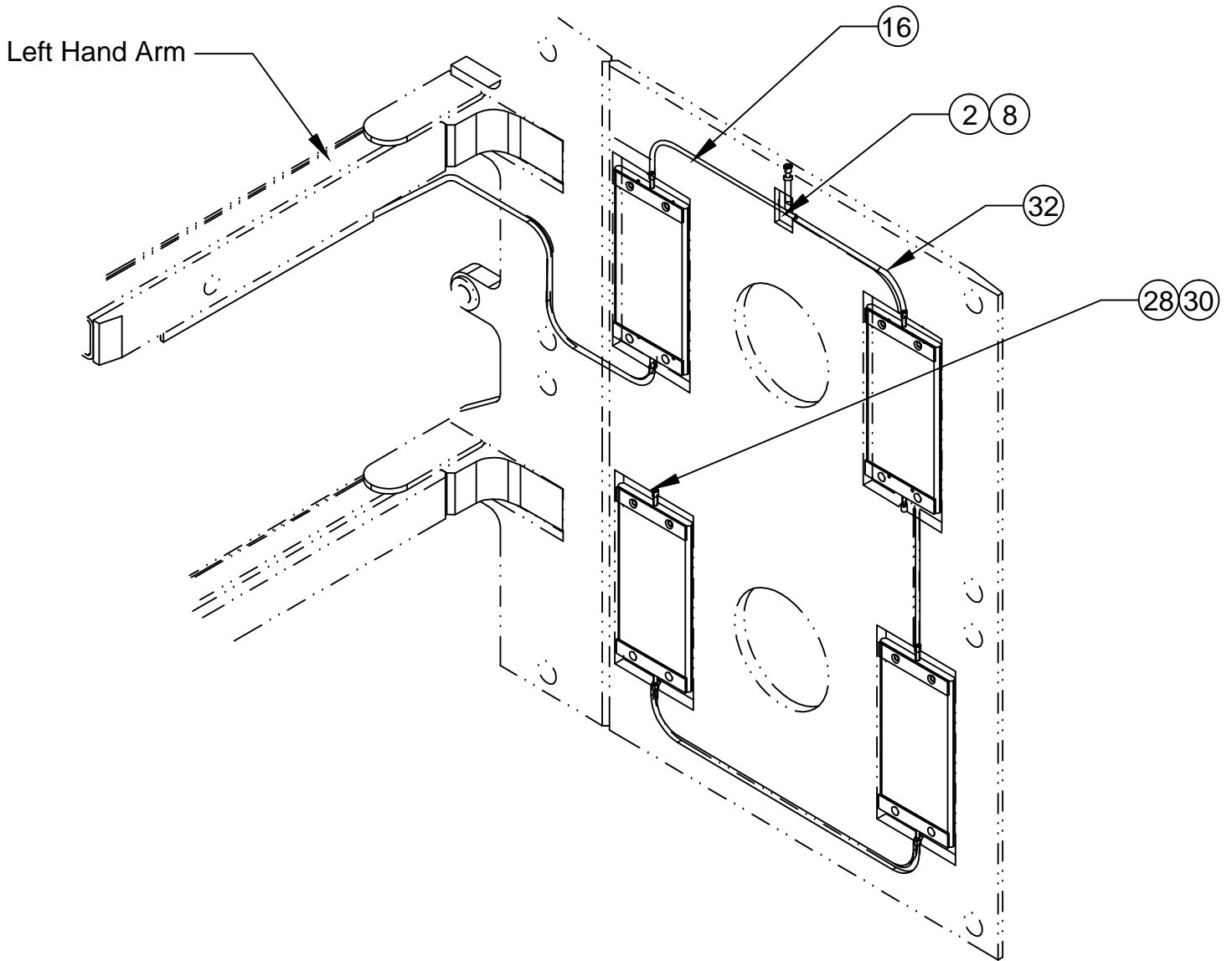

NOTE: Use two 19 gauge stainless steel wire ties (111878) at each bladder connection. Twist to tighten and clip to reduce ends

# HYDRAULIC ASSEMBLY-1

Drawing reference 113007

#	QTY	PART #	DESCRIPTION																				
1	1	111591	Clamp Valve																				
2	2	25G.0524	Bolt																				
3	6	100676.05	Straight Thread Adapter																				
4	2	111518.06	Fitting Adapter																				
5	1	111085	Directional Valve Assembly																				
6	1	100227.05	Fitting Union Tee																				
7	1	111123	In-Line Check Valve																				
8	1	103411.0330	Hose																				
9	1	100674.0395	Hose																				
10	1	100678.05	O-Ring Tee Branch Fitting																				
11	1	100440.05	90° Swivel Fitting																				
12	1	100674.0340	Hose																				
13	1	100674.0245	Hose																				
14	5	100095.05	90° O-Ring Elbow Fitting																				
15	1	100674.0332	Hose																				
16	1	100674.0205	Hose </tr <tr> <td>17</td> <td>1</td> <td>111514</td> <td>Valve Guard</td> </tr> <tr> <td>18</td> <td>1</td> <td>109626.1</td> <td>90° Resistor Fitting</td> </tr> <tr> <td>19</td> <td>1</td> <td>25G.0616</td> <td>Bolt</td> </tr> <tr> <td>20</td> <td>1</td> <td>4F.05</td> <td>Washer</td> </tr> <tr> <td>21</td> <td>1</td> <td>17D.06</td> <td>Nylock Nut</td> </tr>	17	1	111514	Valve Guard	18	1	109626.1	90° Resistor Fitting	19	1	25G.0616	Bolt	20	1	4F.05	Washer	21	1	17D.06	Nylock Nut
17	1	111514	Valve Guard																				
18	1	109626.1	90° Resistor Fitting																				
19	1	25G.0616	Bolt																				
20	1	4F.05	Washer																				
21	1	17D.06	Nylock Nut																				

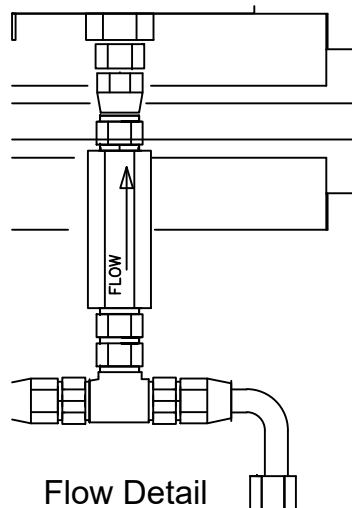
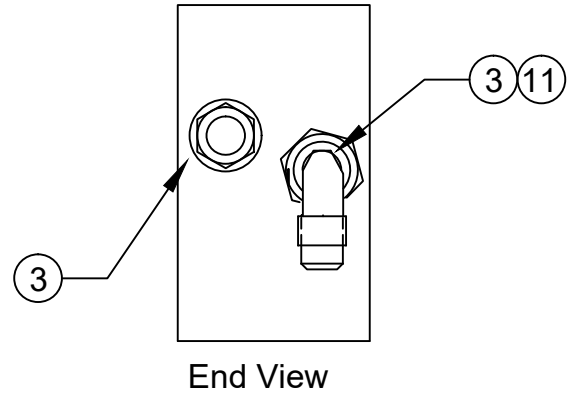

# HYDRAULIC ASSEMBLY-2

Drawing reference 113007

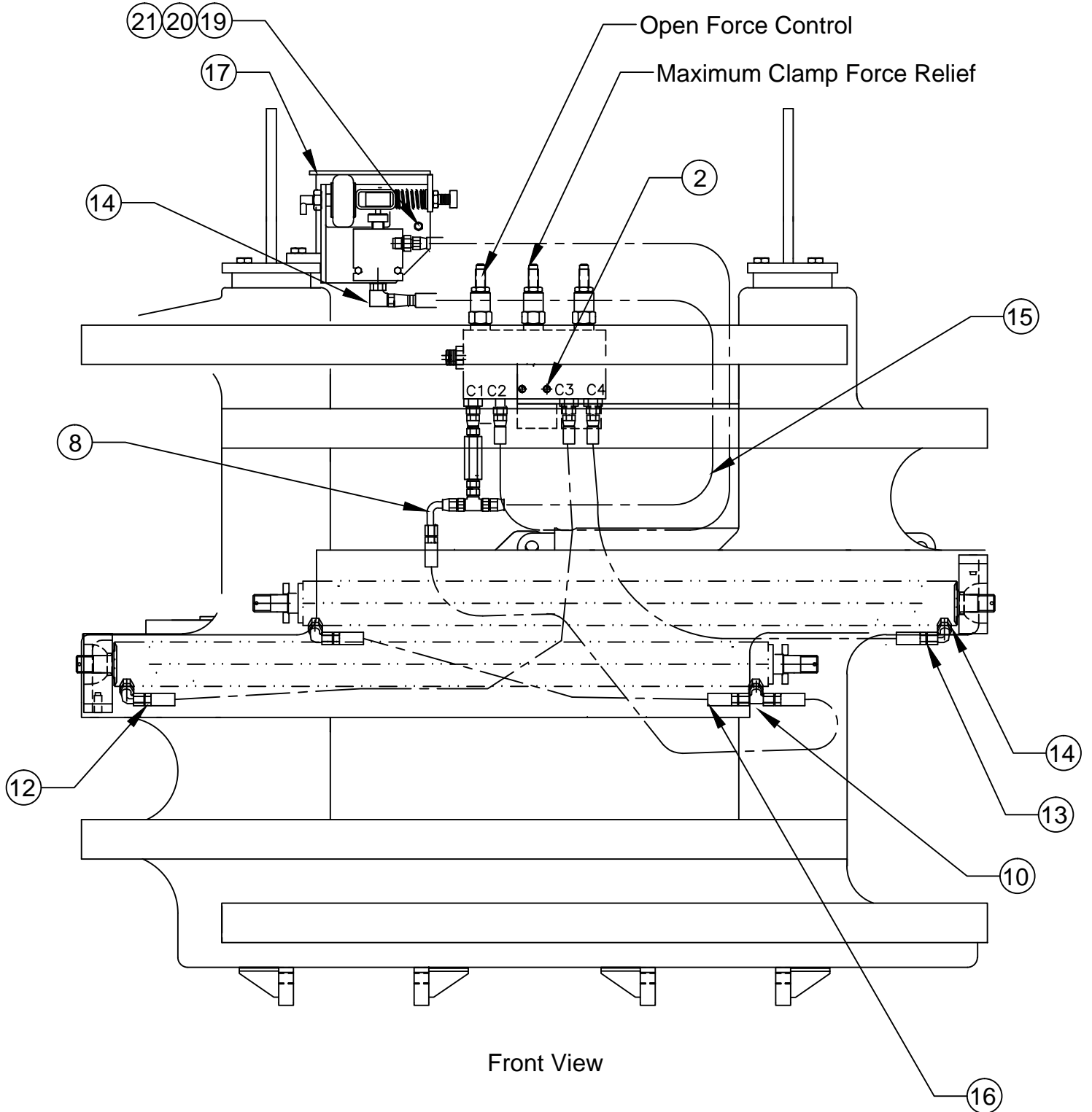

# HYDRAULIC ASSEMBLY-3

Drawing reference 113007

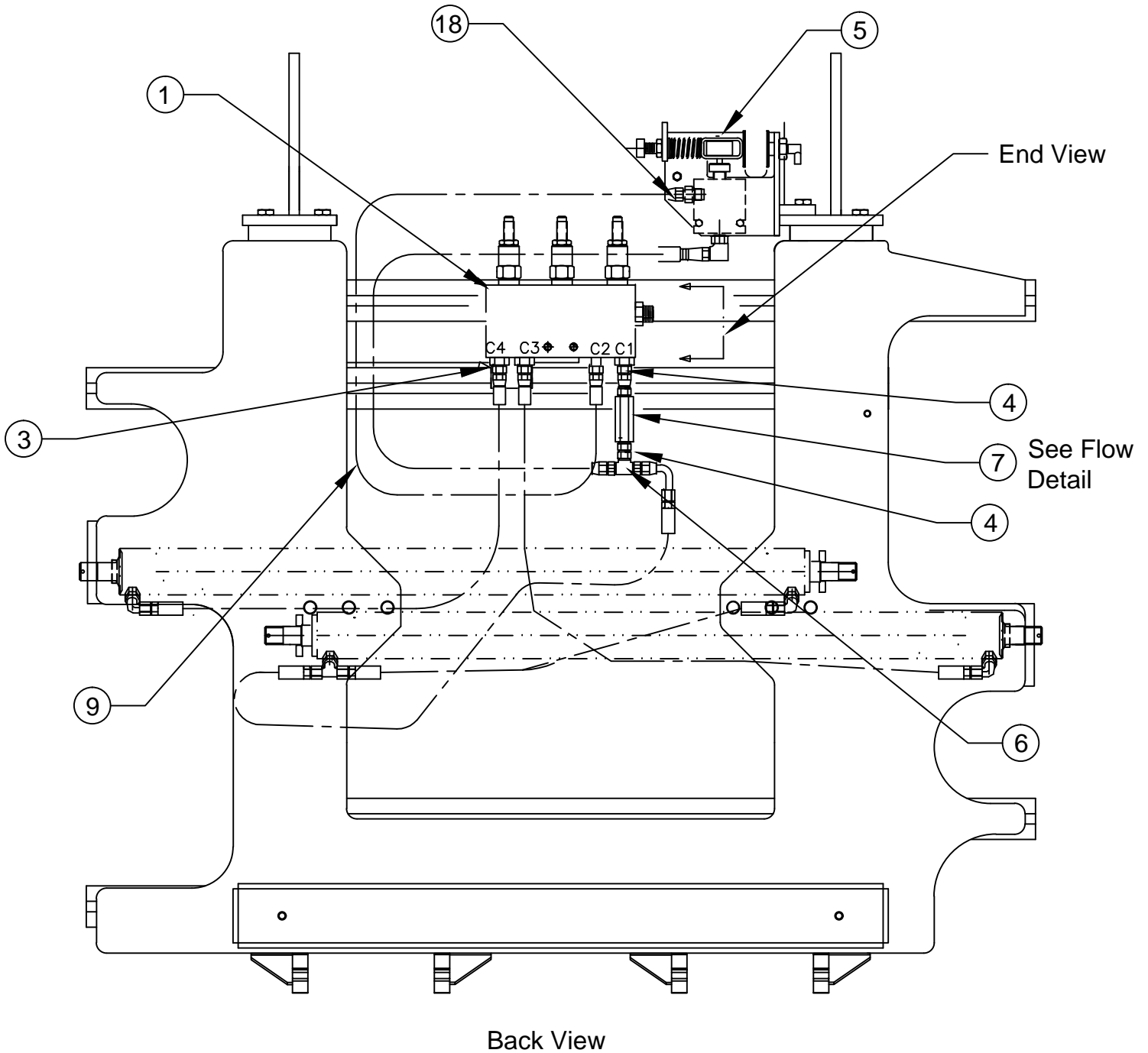

# CYLINDER ASSEMBLY

Drawing reference 111372.3

Part #	R	E	S	NET STROKE
111372.3	34.00	64.00	30.00	30.00

#	QTY	PART #	DESCRIPTION	8	1	100029.2	O-Ring
1	1	111375.3	Tube Weldment	9	1	100028.2	Back-Up Ring
2	1	111379.3	Rod	10	1	10029.201	O-Ring
3	1	111482	Seal Kit (Items 4-10)	11	1	27D.10	Nut Self Locking
4	1	100032.6	Poly-Pak "B"	12	1	100027.7	Lock Wire
5	1	102099.1	Wear Ring	13	1	111374	Piston
6	1	112905	Rod Seal	14	1	111373	Gland
7	1	102098.5	Rod Wiper	15	1	111380	Washer Cylinder

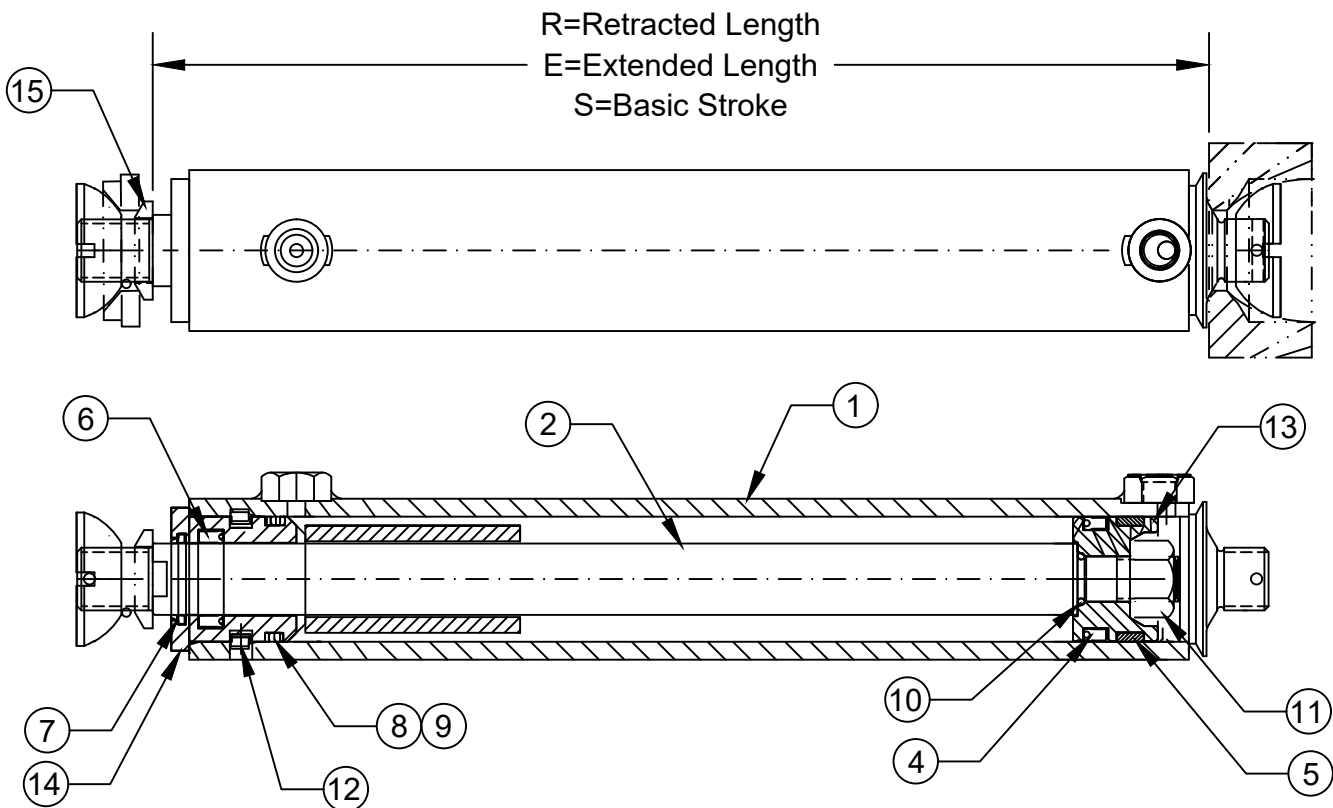

## Cylinder Service

- Prior to assembly lubricate seals, cylinder bore and rod with STP.
- Inspect all parts for scratches, nicks and gouges - replace all damaged components.
- Inspect cylinder bore and rod for scoring - replaced if scored.
- Avoid damage to seal grooves - use a dull screwdriver for seal removal.
- Torque piston nut to 110 FT/LBS. (15.3kg-m).

# CLAMP ADJUSTMENTS

## CLAMP FORCE CHECK/ADJUSTMENT

1. Check water pressure. If out of operating range fill with LORON hand pump # 112909. NOTE: Use pure Propylene Glycol Antifreeze mixed 1 to 1 with water.
2. Check the clamp force.

## CLAMP CONTROL VALVE ADJUSTMENT

NOTE: When looking at the clamp control valve from the front of the clamp, the clevis pin should be directly in front of the shut off valve stem, or slightly to the left, when the clamp will not close. To check the pin position, turn the force control screw in until the clamp just starts to move, at which point the clevis pin should be directly in front of the valve stem.

## OPEN FORCE CHECK/ADJUSTMENT

Open the arms against a force fixture and adjust for desired maximum force.

## SIDE SHIFT FORCE ADJUSTMENT

1. Clamp on the heaviest load that will be handled.
2. Adjust the side shift force down until the arms stop.
3. Turn the adjusting screw one turn in.

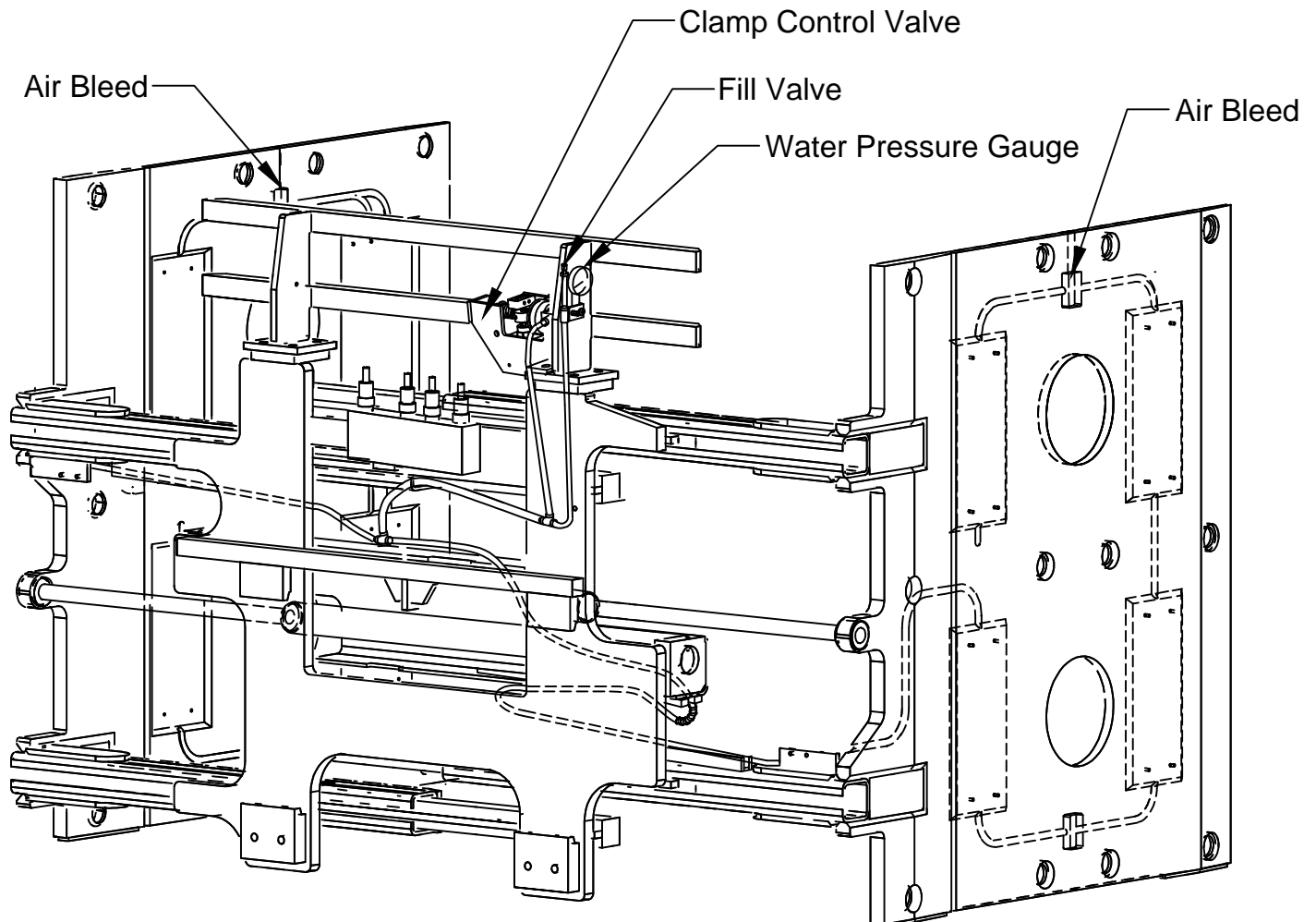

# CONTROL VALVE

Drawing Reference: 111591

(A) **111244** Check Valve  
Torque 30-35 ft-lb  
Seal Kit 112059

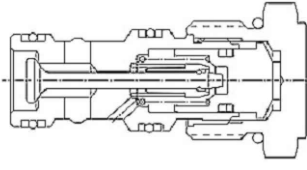

(C) **112887** Flow Divider  
Torque 10-12 ft-lb  
Seal Kit 104711

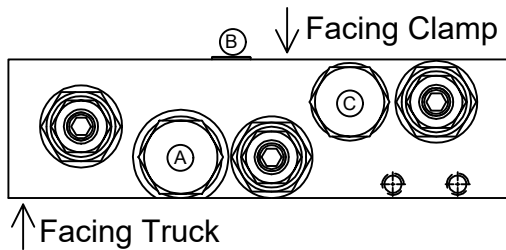
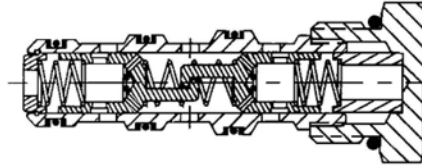

(D) **111627** Pressure Reduce/Relief Valve  
Torque 15-20 ft-lb  
Seal Kit 112065

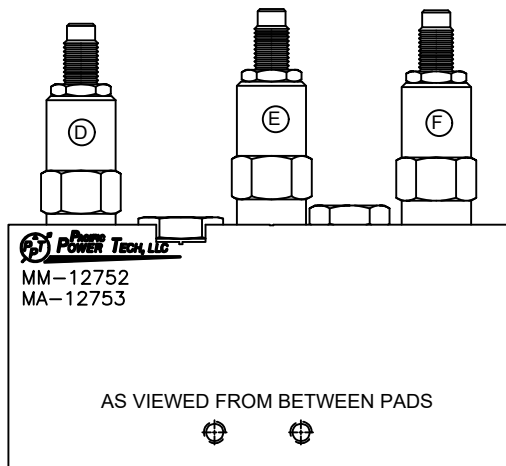
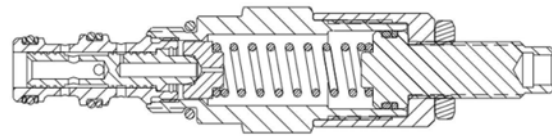

(E) **112406.1** & (F) **112406.2** Bi-Direction Relief Valve  
Torque 20-25 ft-lb  
Seal Kit 112064

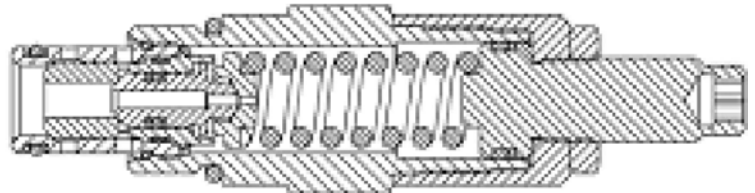

**NOTE:** Lubricate threads & seals prior to assembly.

ID	QTY	PART #	DESCRIPTION
A	1	111244	Check Valve
B	1	00.030 ORIFICE	Orifice
C	1	112887	Flow Divider
D	1	111627	Pressure Reducer Valve
E	1	112406.1	Bi-Direction Relief Valve
F	1	112406.2	Bi-Direction Relief Valve

## HYDRAULIC SCHEMATIC

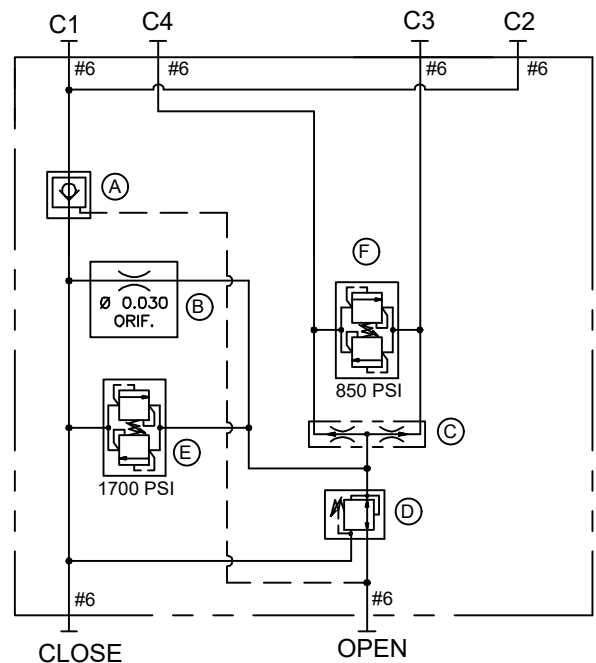



# CLAMP FORCE CONTROL VALVE

Drawing reference 111085

#	QTY	PART #	DESCRIPTION
1	1	11G.0844	Bolt
2	1	111573	Mounting Plate Weldment
3	1	111094	Directional Valve
4	2	4E.04	Lock Washer
5	1	7D.08	Jam Nut
6	1	110906	Wheel
7	1	111091	Air Spring
8	2	1C.0424	Bolt
9	1	7D.10	Hex Nut
10	1	111328	Wheel Housing
11	1	111097	Spring
12	1	111098	Spring Tension Cap
13	1	111572	Spring Cap
14	1	111655	Clevis Pin
15	1	100574.28	Cotter Pin
16	1	113234	Nylon Washer
17	1	15G.0408	Set Screw
18	1	113233	Washer
19	1	113235	Nylon Washer

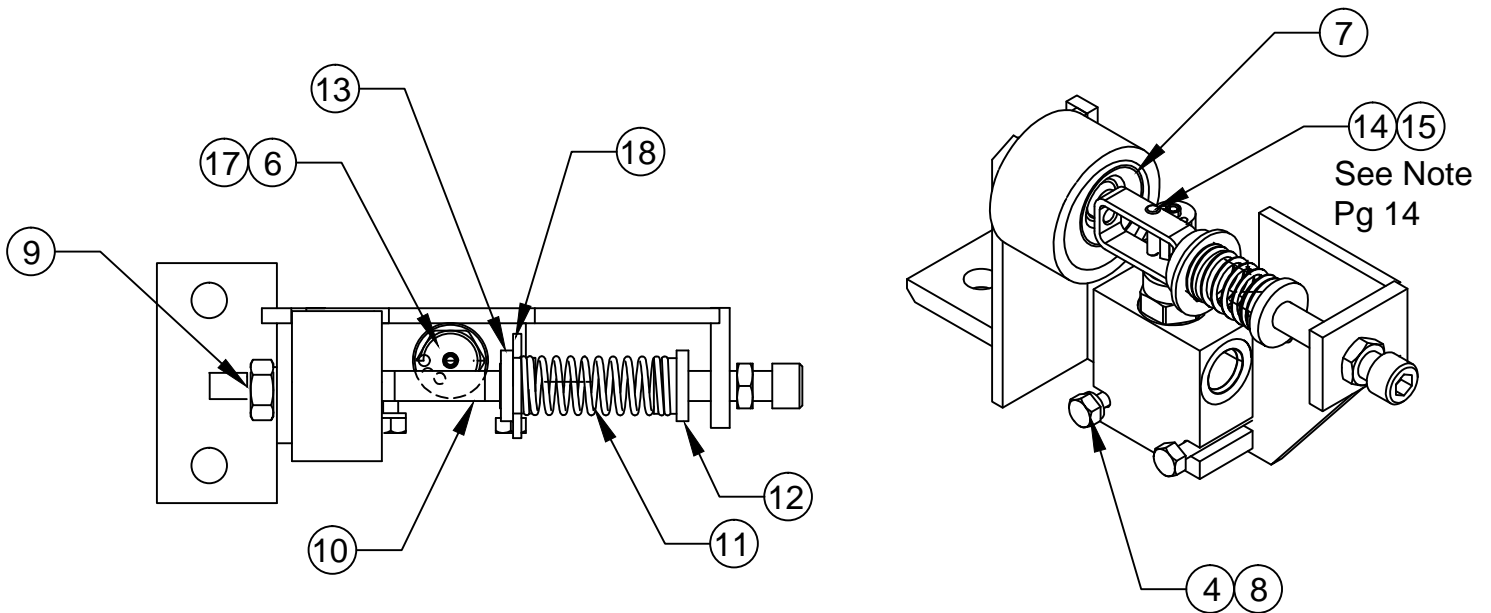

Reference 111289 see floating pads assembly

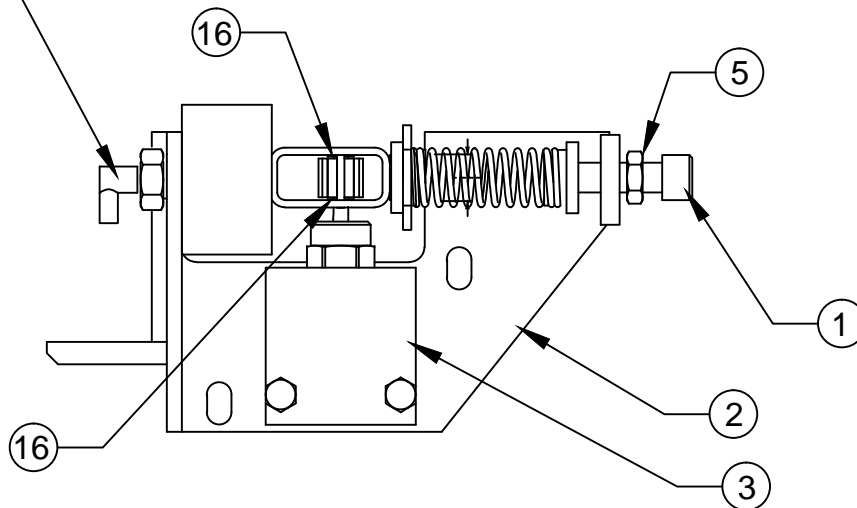

---

---

# ARM SLIDE & SHIM REPLACEMENT

---

---

1. To replace the slides, the arms need to be in the fully open position. Release system pressure prior to removing the arms by turning the truck off and working the side shift and clamp function controls several times.
2. Support the arm with an overhead crane or lift truck. Be sure to secure the chain or sling in a manner that prevents the arm from falling out of the chain or sling when hanging free of the clamp.
3. Remove the cotter pin, slotted nut and spherical bearing from the end of the clamp cylinder rod. Keeping hands and feet clear, and carefully slide the clamp arm off of the clamp frame.
4. Inspect slides and slide buttons for wear. Slides may be rotated end-to-end and reused if excessively worn on the outer end only. Extra shims may be used to tighten operating clearance on slightly worn slides. Replace any slides worn to less than 0.15" (3.8mm) thick or any slide that is deeply scored or broken.

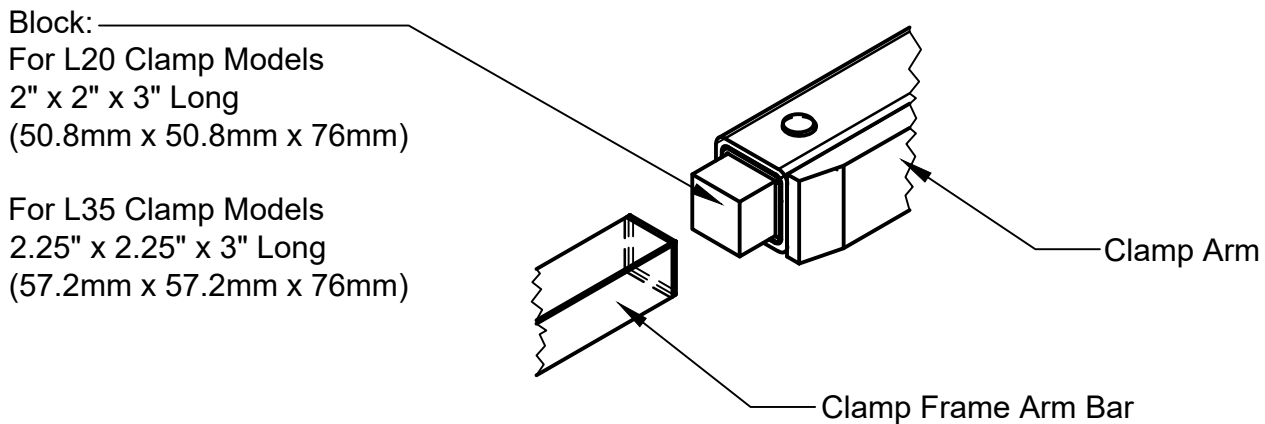

5. To aid in replacing the slides a block may be fashioned of wood or another convenient material to the dimensions shown above. The block is inserted to the end of the arm to hold the slides, shims, and buttons in position while the arm is inserted over the arm bars on the clamp frame. The block is expelled out the opposite end of the arm as the arm is pushed onto the frame. Prior to installing the arm the block may be used to determine the number of shims to place under the slides. Adjust the clearance between the slides and the block to provide approximately .06" (1.5mm) running clearance between the slides and arm when installed.
6. Keeping hands and feet clear, carefully slide the clamp arm onto the clamp frame. Be sure the arm moves freely without excessive binding. If the arm is too loose or too tight add or remove shims as required.
7. Install the spherical bearing, slotted nut and cotter pin onto the end of the clamp cylinder rod. Be sure to leave .03"-.06" (.7mm to 1.5mm) clearance to allow the cylinder to "float" on its mountings.

---

---

# TROUBLE SHOOTING GUIDE

---

---

## LOADS SLIPPING OR DROPPING

### POSSIBLE CAUSES

### SOLUTION

- |  |  |
|--|--|
| 1. Clamp force set too low.                                      | 1. Adjust clamp force.   |
| 2. Internal leakage in cylinder.                                 | 2. Replace cylinder seals. If tube, pistons or rod is scored replace with new parts. |
| 3. Load too heavy for the clamp capacity.                        | 3. Consult factory.  |
| 4. Load may not be stacked correctly or may need to be unitized. | 4. Restack or unitize load (shrink wrap).  |
| 5. Bent arms or contact pads.                                    | 5. Consult factory.  |
| 6. Damaged / leaking hydraulic hose                              | 6. Replace damaged hose.   |

## CRUSHING LOADS

### POSSIBLE CAUSES

### SOLUTION

- |                                |                                |
|--------------------------------|--------------------------------|
| 1. Clamp force set too high.   | 1. Adjust clamp force.         |
| 2. Bent arms or contact pads.  | 2. Consult factory.            |
| 3. Leak in the bladder system. | 3. Check for leaks and repair. |

## ARM CHATTERING OR ERRATIC MOVEMENT

### POSSIBLE CAUSES

### SOLUTION

- |   |  |
|---|--|
| 1. Bent clamp arms.   | 1. Consult factory.  |
| 2. Nylon slides sticking.<br>Note: Sticking slides can cause inconsistent force measurements. | 2. Clean slides if necessary, the slides are self lubricating. |
| 3. Nylon slides worn, broken or missing.  | 3. Replace damaged slides, shims, and retaining buttons.       |