

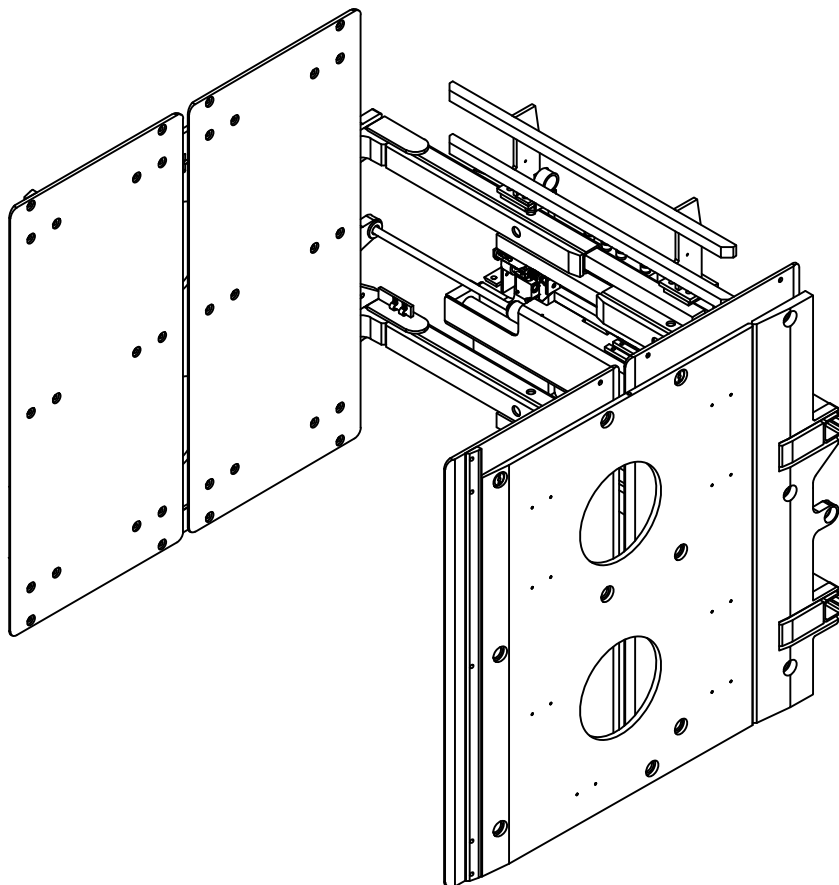

SERVICE MANUAL / PARTS LIST

APPLIANCE CLAMP SOFT TOUCH

MODEL #113072
PATENT NO. 9,630,821
PATENT NO. 10,597,272



CONTENT:

PAGE

1	Lift Truck Requirements General Installation Procedures General Inspection & Maintenance
2-4	Clamp Assembly
5	Arm Group Assembly
6-8	Floating Pad Assembly
9-10	Hydraulic Assembly
11	Cylinder Assembly
12	Clamp Adjustments
13	Control Valve
14	Clamp Force Control Valve
15	Arm Slide & Shim Replacement
16	Trouble Shooting Guide

Specifications:

Mounting: Class II
Side Shifting: External Side Shifting
Capacity: 2200 lbs at 29"
Pad Size: 57" High x 58" Long
Range: 23.0" - 80.0"
Frame: 46" Wide

R0 - 06/2017

425 Hazel St.
Kelso WA 98626
(800) 248-6079
Fax (360) 578-9934

LIFT TRUCK REQUIREMENTS

Capacity shown on the clamp's name plate is for the clamp only. The combined truck and clamp capacity is provided by the lift truck manufacturer.

Recommended Truck Pressure: 2300 to 2400 PSI (159 to 165 bar).

Hydraulic fluid: petroleum based hydraulic fluid only.

Hydraulic supply group: includes hoses and take-up - one for each function.

Auxiliary valves: 2 function (Side Shift & Clamp) = double auxiliary valve.

Oil Volume Settings:

Side Shift = 3 GPM

Clamp Open/Close = 7 GPM

NOTE: Three Position Force Selector must be disabled.

GENERAL INSTALLATION PROCEDURES

1. Make sure that the attachment centering lug is correctly seated in truck carriage center notch.
2. Clearance between the lower retainers that hold the attachment to the truck lower carriage bar should be as shown below.

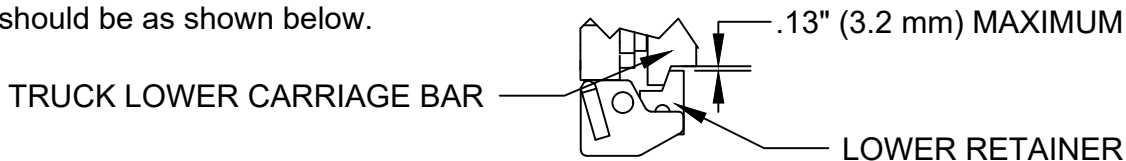

3. Connect hydraulic jumper hoses from the truck's supply group to the attachment's main manifold.
4. Standing clear of the clamp attachment, cycle the attachment in and out several times. Partially filled hydraulic lines may cause erratic movement.

GENERAL INSPECTION AND MAINTENANCE

1. Check all hydraulic fittings, hoses, cylinders and valves for leakages - repair or replace as required.
2. Check bladder system pressure. If out of operating range adjust as required using the LORON hand pump (PN: 112909) and pure propylene glycol antifreeze mixed 1:1 with water. Check clamp force and adjust.
Time Schedule: Check bladder pressure every day and clamp forces every 3 weeks
Bladder System Pressure: 4 - 6 PSI
3. All bolts should be checked and tightened as required.
4. Check lower retainer clearance - see item 2 in the General Installation Procedures above.

CLAMP ASSEMBLY-1

Drawing reference 113071.1

#	QTY	PART #	DESCRIPTION				
				19	1	100106	Cylinder Assembly
1	1	111610	Frame Weldment	20	1	113028	Hook Weldment
2	2	111372.3	Cylinder Assembly	21	6	11G.1040	Bolt
3	1	111652.1	Load Backrest	22	6	16E.10	Lock Washer
4	8	1C.0820	Bolt	23	2	108421	Slide II
5	8	4E.08	Lock Washer	24	1	113029	Cylinder Anchor Weldment
6	4	110731	Spherical Bearing	25	1	111357.2	Lower Slide
7	4	110730	Spherical Seat	26	1	111594.1	Shim
8	4	100574.86	Cotter Pin	27	1	9G.0816	Bolt
9	2	111380	Cylinder Rod Washer	28	1	100095.05	Fitting
10	2	107870	Lower Retainer	29	1	100222.1	Restrictor Fitting
11	2	11G.08136	Bolt	30	2	100075.14	Grease Fittings
12	2	17D.08	Nut Nylock	31	1	108272	Brass Set Screw
13	1	111059	Cylinder Guard	32	1	7D.06	Jam Nut
14	4	25GN.0612	Bolt	33	2	11G.0808	Bolt
15	4	109528	Nord-Lock Washer	34	2	16E.08	Lock Washer
16	1	111090	Cover Weldment	35	1	111662	Bumper
17	2	25G.0512	Bolt	36	4	100029.314	O-Ring
18	2	4E.05	Lock Washer				

CLAMP ASSEMBLY-2

Drawing reference 113071.1

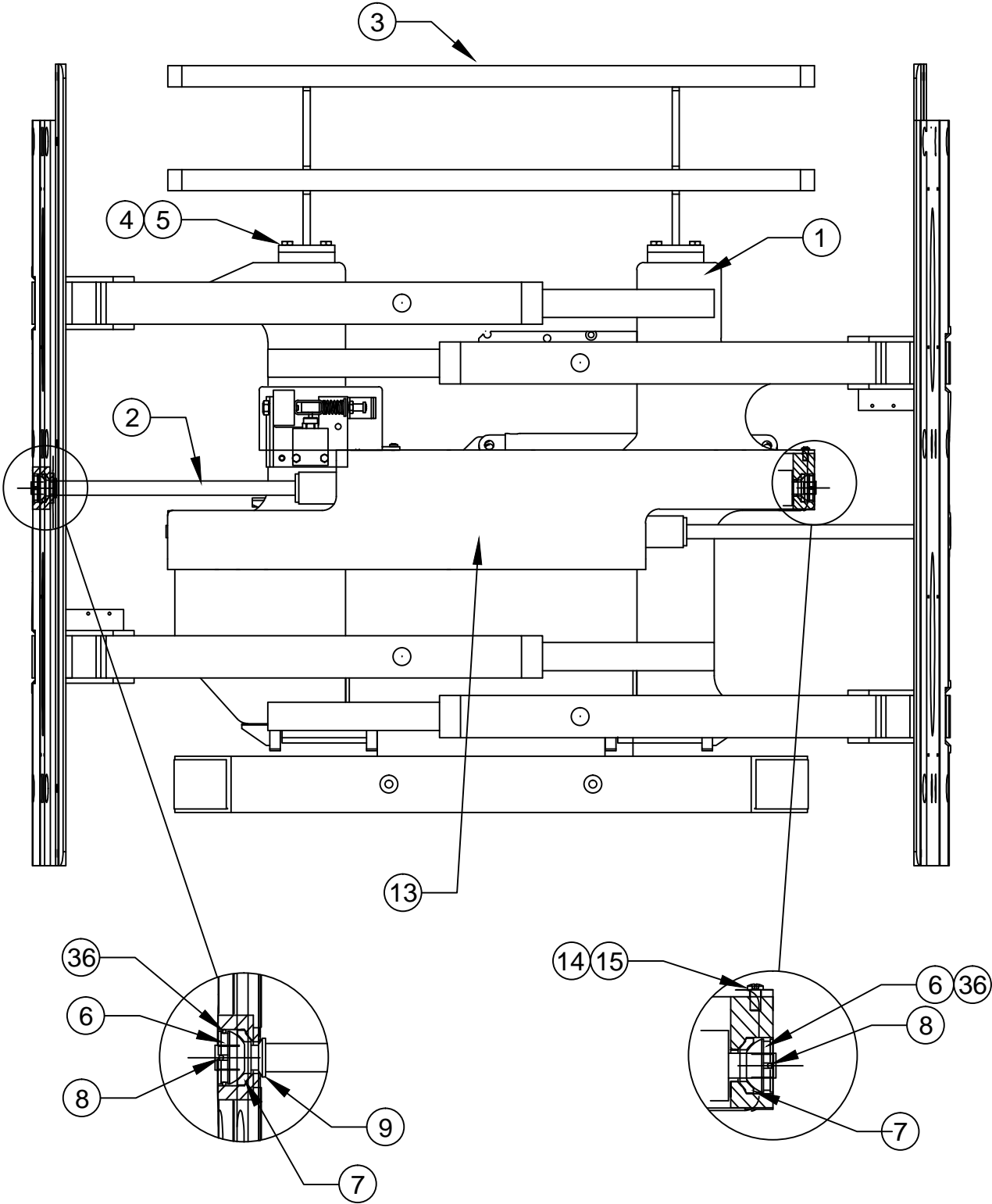

CLAMP ASSEMBLY-3

Drawing reference 113071.1

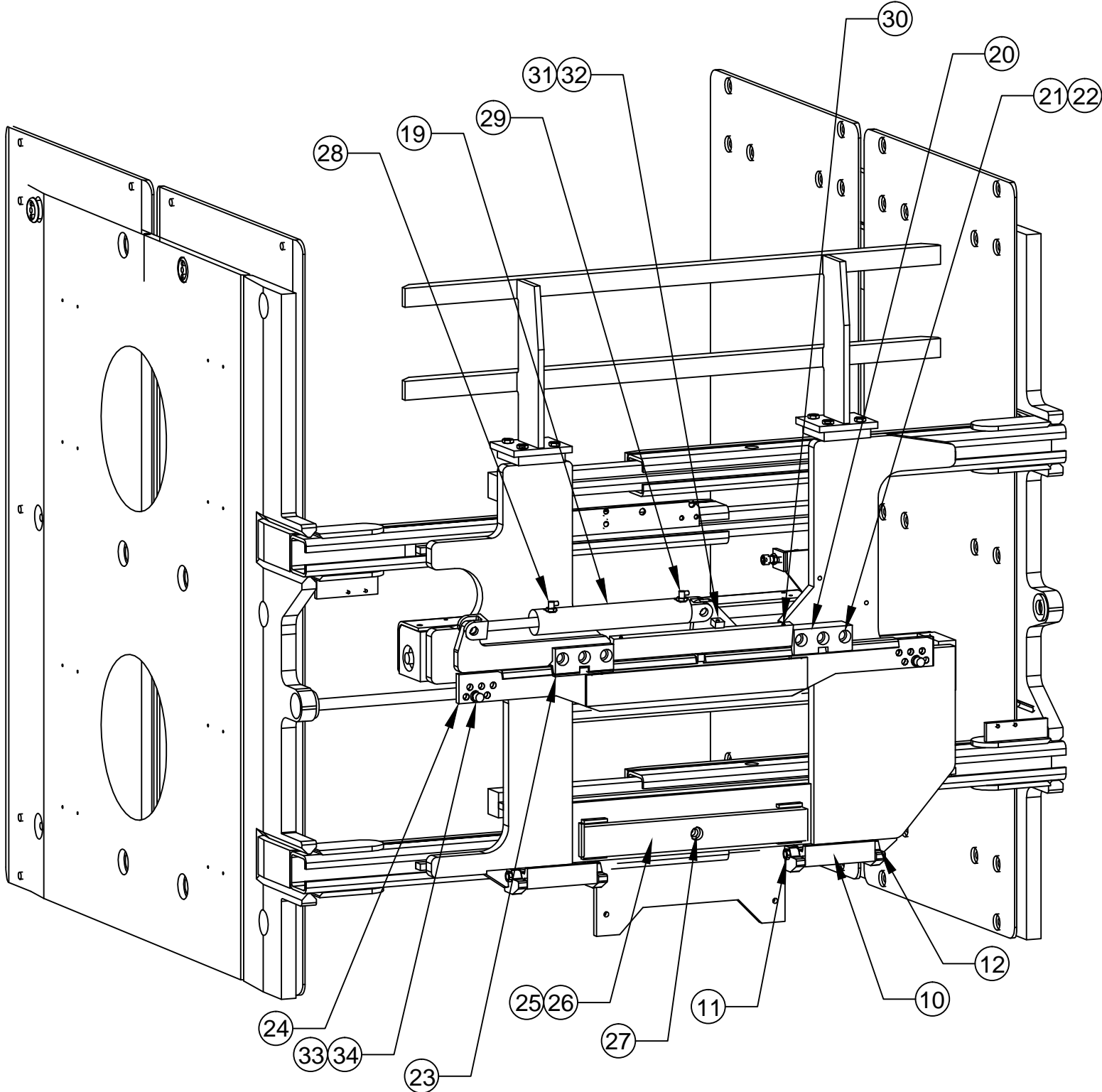

ARM GROUP ASSEMBLY

Drawing reference 111582.1

#	QTY	PART #	DESCRIPTION
1	1	111617	Right Hand Arm Weldment
2	1	111618	Left Hand Arm Weldment
3	4	111608	Contact Pad
4	24	111031	Retaining Nut
5	1	111609	Right Hand Tip Plate
6	1	111609	Left Hand Tip Plate
7	24	1C.0820	Bolt
8	10	1C.0812	Bolt
9	34	108088	Spring Washer
10	4	111622.1	Flat Slide
11	8	111621.1	Angle Slide
12	12	109212.4	Shim
13	12	111619	Slide Button

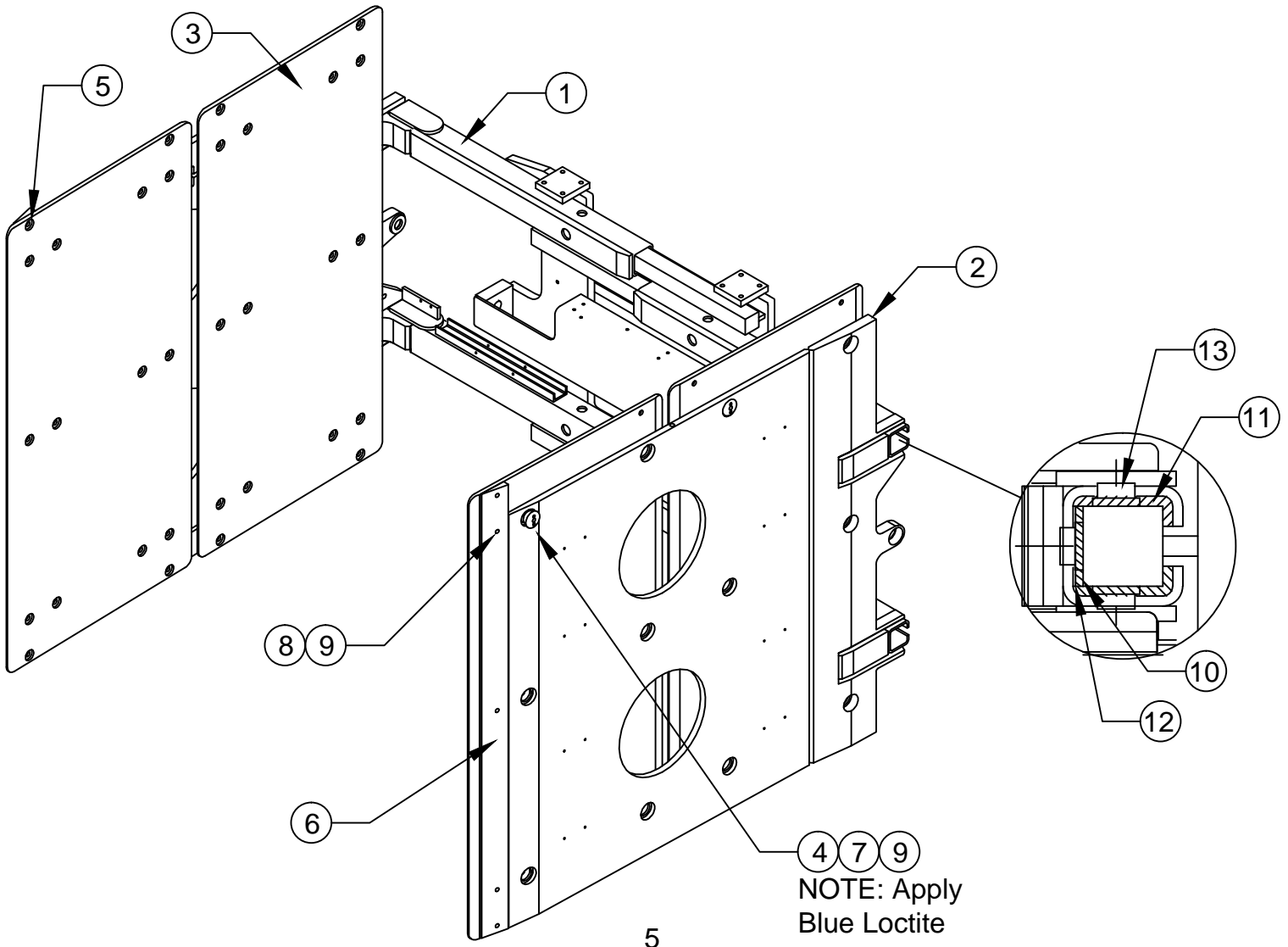

FLOATING PAD ASSEMBLY-1

Drawing reference 111596.1

#	QTY	PART #	DESCRIPTION	18	2	111290.0350	Hose
1	3	111350	Air Tank Valve	19	8	111030	Bladder
2	18	111295	Hose Clamp	20	32	9G.0412	Bolt
3	1	111290.0025	Hose	21	16	111471	Clamp Bar
4	1	111296	Pressure Gauge	22	8	109256	Hose Clamp
5	1	111543.01	90° Elbow Fitting	23	8	25G.0508	Bolt
6	1	111292	Branch Tee	24	2	113026.0360	Cover Hose
7	1	111290.0177	Hose	25	4	111128	Hose Guide
8	4	111293	Run Tee	26	12	1C.0512	Bolt
9	1	111290.0157	Hose	27	1	111289	Pipe Elbow
10	1	111290.0060	Hose	28	2	111654	Plug
11	1	111290.0895	Hose	29	2	111510	Spring
12	1	111290.0925	Hose	30	VARIABLES	111878	19 Gauge Stainless Wire Tie
13	1	111299	Hose Clip	31	3	111653	Valve Cap
14	1	25G.0520	Bolt	32	1	111085	Direction Valve Assembly
15	2	111290.0027	Hose	33	1	113018	Cable Tab
16	4	111290.0164	Hose	34	2	113416	Hose Channel
17	2	111290.0136	Hose	35	8	3G.0808	Bolt

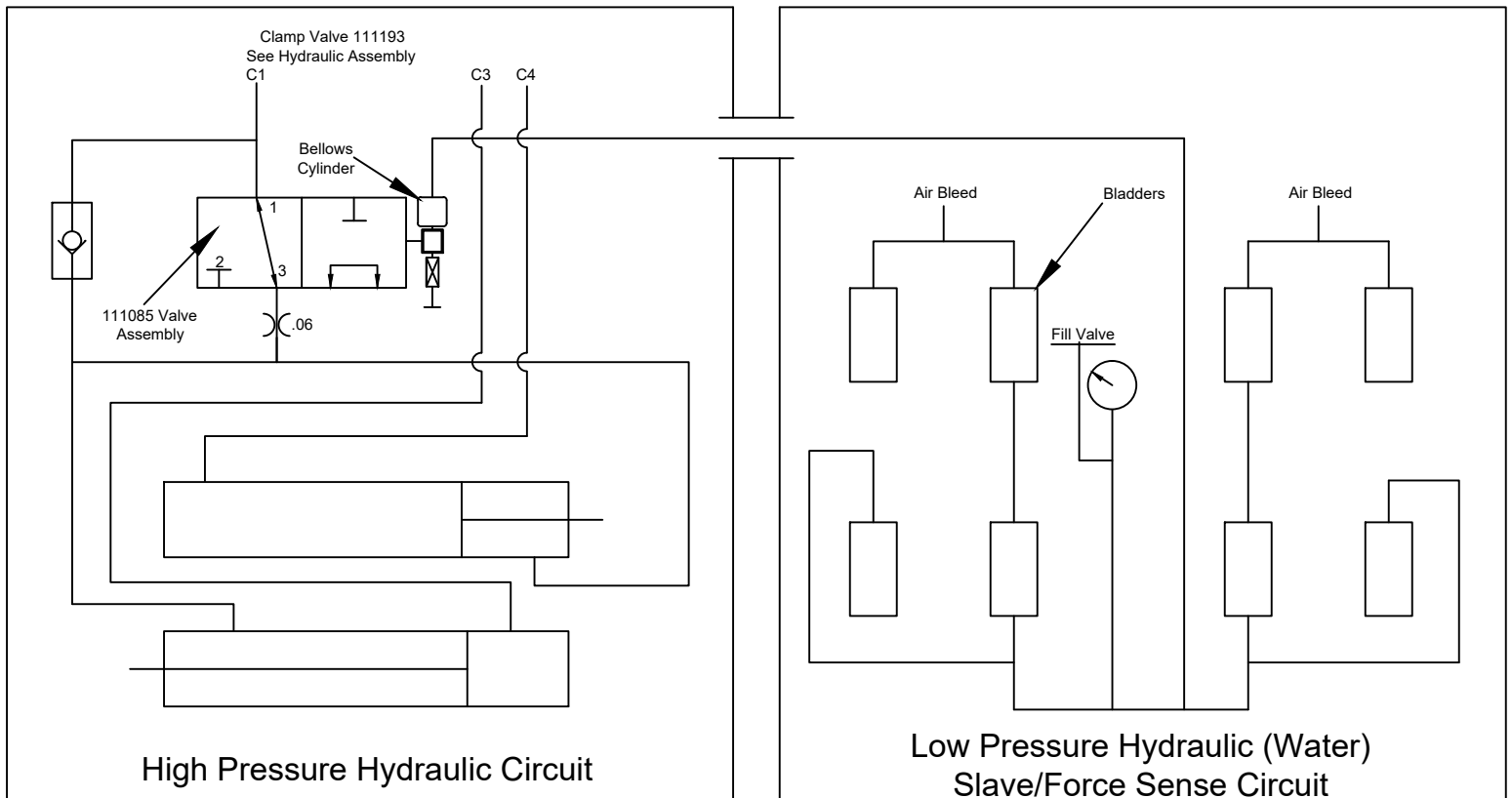

FLOATING PAD ASSEMBLY-2

Drawing reference 111596.1

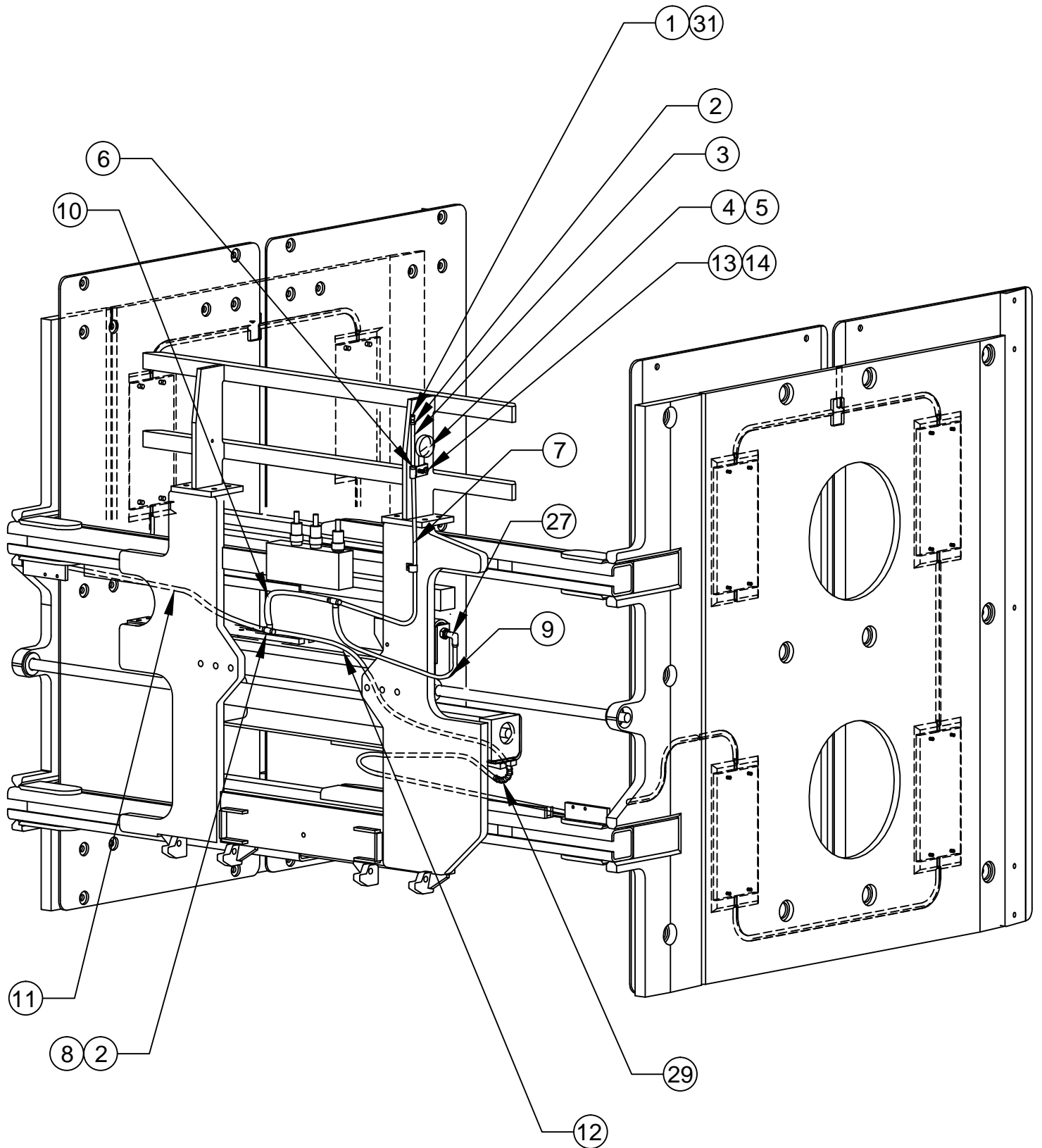

FLOATING PAD ASSEMBLY-3

Drawing reference 111596.1

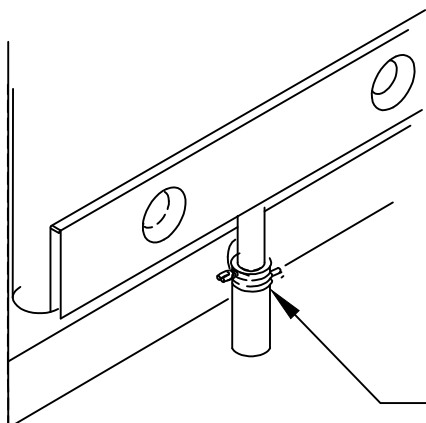
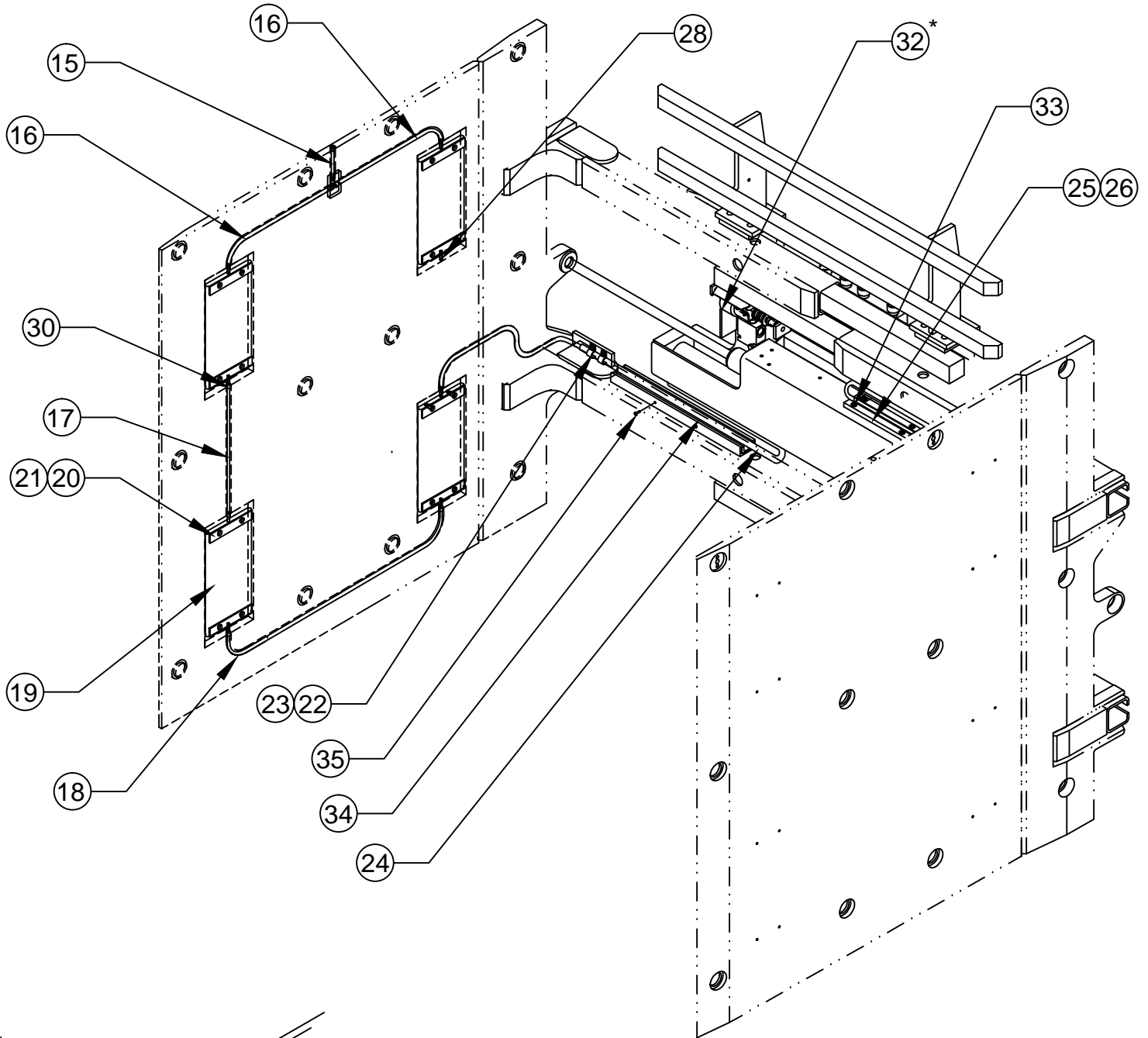

NOTE: Use two 19 gauge stainless steel wire ties (111878) at each bladder connection. Twist to tighten and clip to reduce ends

HYDRAULIC ASSEMBLY-1

Drawing reference 111584

#	QTY	PART #	DESCRIPTION
1	1	111591	Clamp Valve
2	2	25G.0524	Bolt
3	4	100676.05	Straight Thread Adapter
4	1	100674.0170	Hose Assembly
5	1	111085.1	Directional Valve Assembly
6	1	100232.05	Swivel Tee Fitting
7	1	111073.05	Straight Pipe to Swivel Adapter
8	1	111123	In-Line Check Valve
9	1	100432.05	Male JIC 06 To Male Pipe 1/4"-18 Adapter
10	1	100674.0300	Hose Assembly
11	1	100678.05	O-Ring Tee Branch Fitting
12	1	100674.0320	Hose Assembly
13	1	100674.0250	Hose Assembly
14	4	100095.05	90° Elbow Fitting
15	1	100674.0400	Hose Assembly
16	1	100674.0205	Hose Assembly
17	2	1C.0616	Bolt
18	2	4E.06	Lock Washer
19	1	109626.1	O-Ring Straight Restrictor Fitting
20	1	102512.05	O-Ring Tee Fitting
21	1	100440.05	Swivel Elbow Fitting

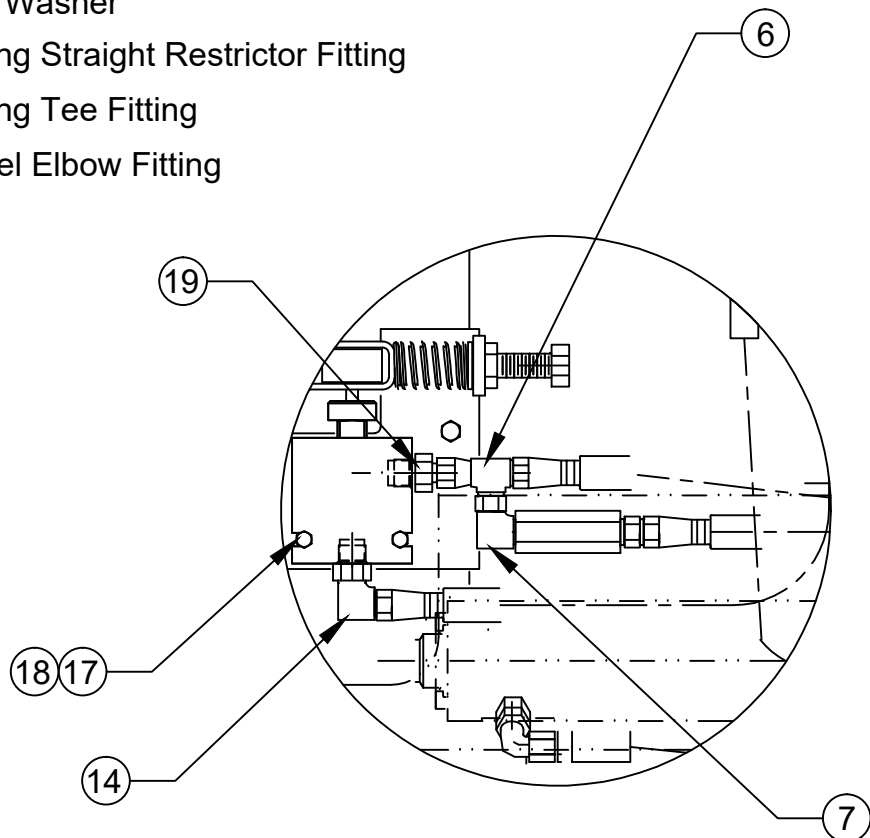

HYDRAULIC ASSEMBLY-2

Drawing reference 111584

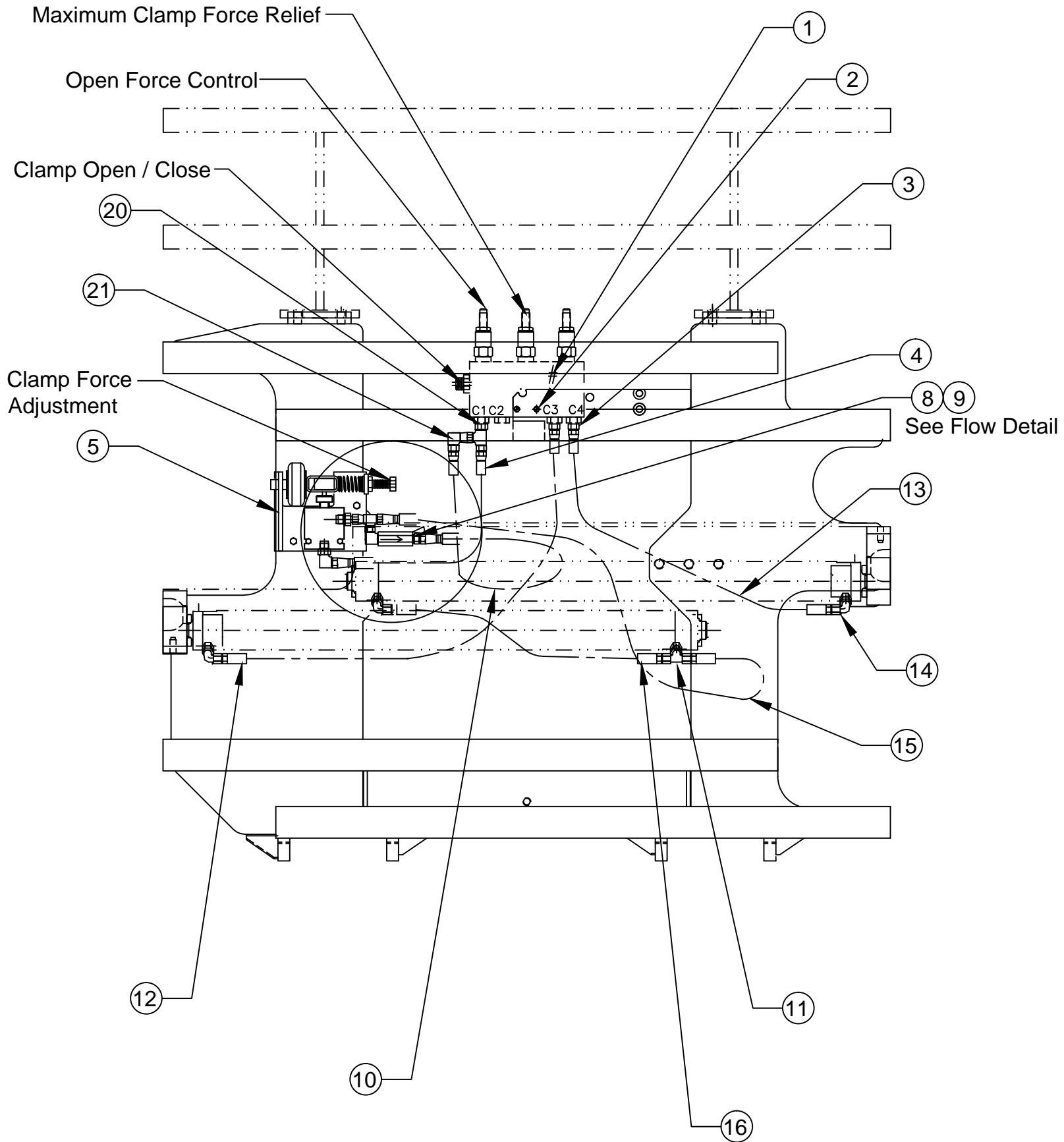

CYLINDER ASSEMBLY

Drawing reference 111372.3

Part #	R	E	S	NET STROKE
111372.3	34.00	64.00	30.00	30.00

#	QTY	PART #	DESCRIPTION	8	1	100029.2	O-Ring
1	1	111375.3	Tube Weldment	9	1	100028.2	Back-Up Ring
2	1	111379.3	Rod	10	1	100029.201	O-Ring
3	1	111482	Seal Kit (Items 4-10)	11	1	27D.10	Nut Self Locking
4	1	100032.6	Poly-Pak "B"	12	1	100027.7	Lock Wire
5	1	102099.1	Wear Ring	13	1	111374	Piston
6	1	112905	Rod Seal	14	1	111373	Gland
7	1	102098.5	Rod Wiper	15	1	111380	Washer Cylinder

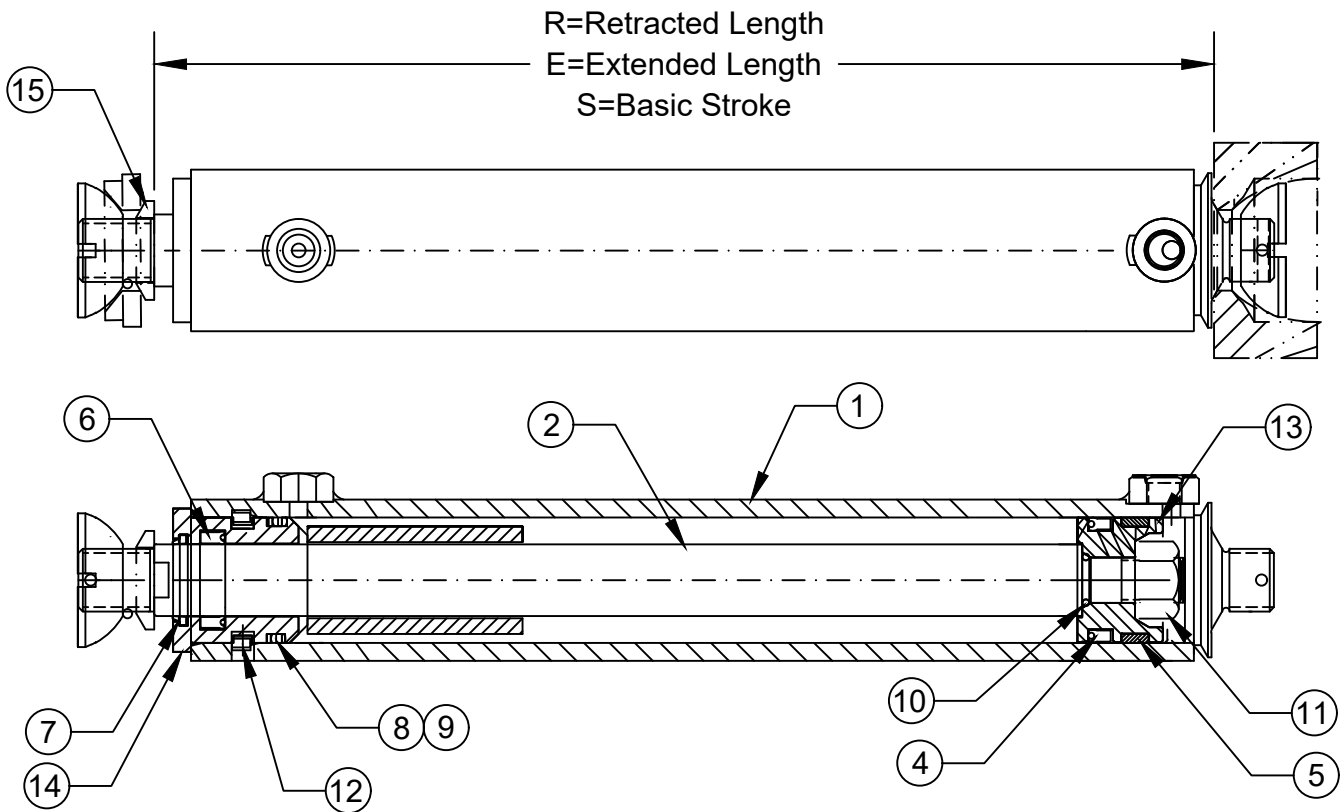

Cylinder Service

- Prior to assembly lubricate seals, cylinder bore and rod with STP.
- Inspect all parts for scratches, nicks and gouges - replace all damaged components.
- Inspect cylinder bore and rod for scoring - replaced if scored.
- Avoid damage to seal grooves - use a dull screwdriver for seal removal.
- Torque piston nut to 110 FT/LBS. (15.3kg-m).

CLAMP ADJUSTMENTS

CLAMP FORCE CHECK/ADJUSTMENT

1. Check water pressure. If out of operating range fill with LORON hand pump # 112909. NOTE: Use pure Propylene Glycol Antifreeze mixed 1 to 1 with water.
2. Check the clamp force.

CLAMP CONTROL VALVE ADJUSTMENT

NOTE: When looking at the clamp control valve from the front of the clamp, the clevis pin should be directly in front of the shut off valve stem, or slightly to the left, when the clamp will not close. To check the pin position, turn the force control screw in until the clamp just starts to move, at which point the clevis pin should be directly in front of the valve stem.

OPEN FORCE CHECK/ADJUSTMENT

Open the arms against a force fixture and adjust for desired maximum force.

SIDE SHIFT FORCE ADJUSTMENT

1. Clamp on the heaviest load that will be handled.
2. Adjust the side shift force down until the arms stop.
3. Turn the adjusting screw one turn in.

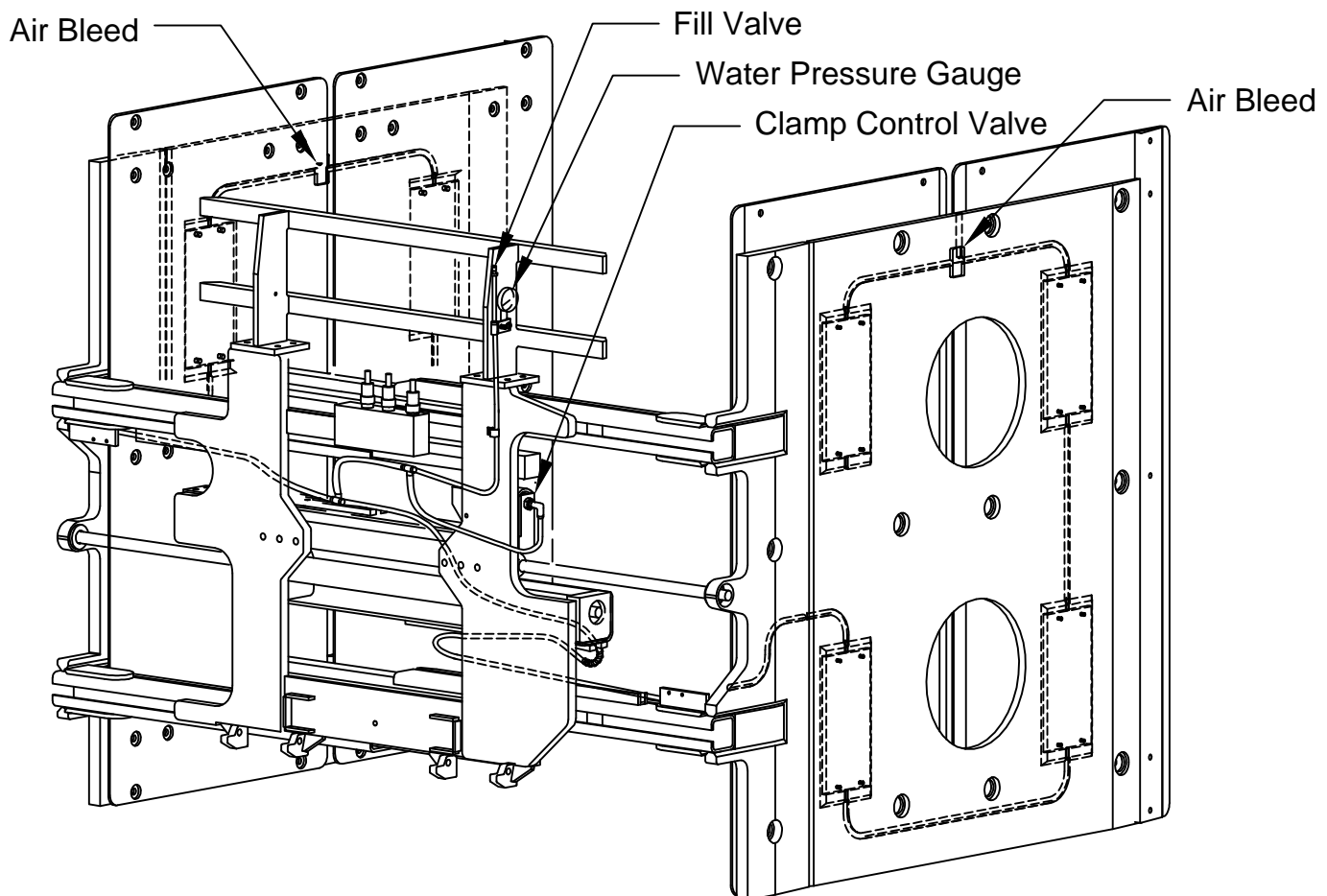

CONTROL VALVE

Drawing Reference: 111591

(A) **111244** Check Valve
Torque 30-35 ft-lb
Seal Kit 112059

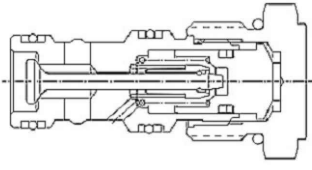

(C) **112887** Flow Divider
Torque 10-12 ft-lb
Seal Kit 104711

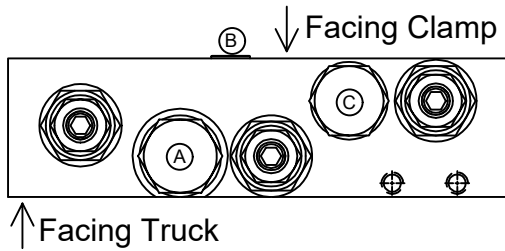
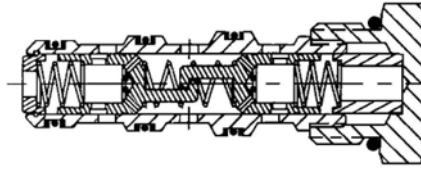

(D) **111627** Pressure Reduce/Relief Valve
Torque 15-20 ft-lb
Seal Kit 112065

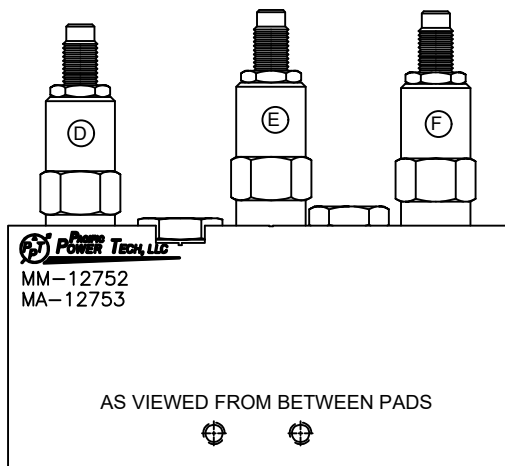
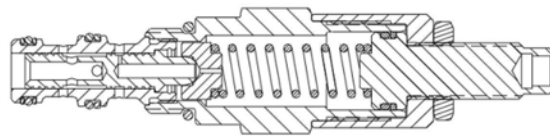

(E) **112406.1** & (F) **112406.2** Bi-Direction Relief Valve
Torque 20-25 ft-lb
Seal Kit 112064

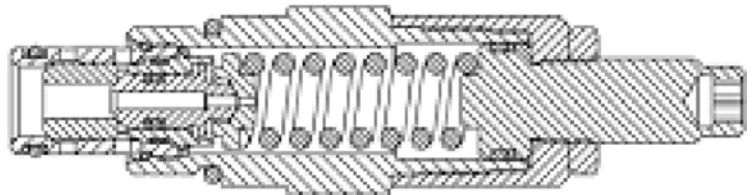

NOTE: Lubricate threads & seals prior to assembly.

ID	QTY	PART #	DESCRIPTION
A	1	111244	Check Valve
B	1	00.030 ORIFICE	Orifice
C	1	112887	Flow Divider
D	1	111627	Pressure Reducer Valve
E	1	112406.1	Bi-Direction Relief Valve
F	1	112406.2	Bi-Direction Relief Valve

HYDRAULIC SCHEMATIC

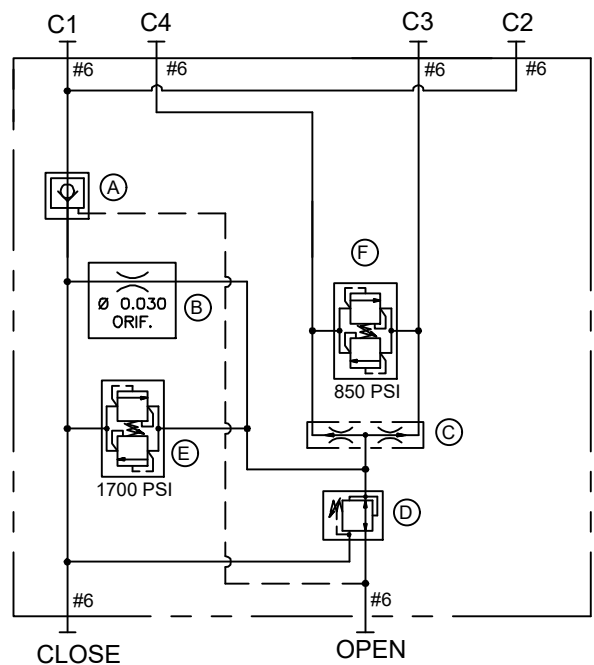

CLAMP FORCE CONTROL VALVE

Drawing reference 111085.1

#	QTY	PART #	DESCRIPTION
1	1	11G.0844	Bolt
2	1	111092	Mounting Plate Weldment
3	1	111094	Directional Valve
4	2	4E.04	Lock Washer
5	1	7D.08	Jam Nut
6	1	110906	Wheel
7	1	111091	Air Spring
8	2	1C.0424	Bolt
9	1	7D.10	Hex Nut
10	1	111328	Wheel Housing
11	1	111097	Spring
12	1	111098	Spring Tension Cap
13	1	111572	Spring Cap
14	1	111655	Clevis Pin
15	1	100574.28	Cotter Pin
16	1	113234	Nylon Washer
17	1	15G.0408	Set Screw
18	1	113233	Washer
19	1	113235	Nylon Washer

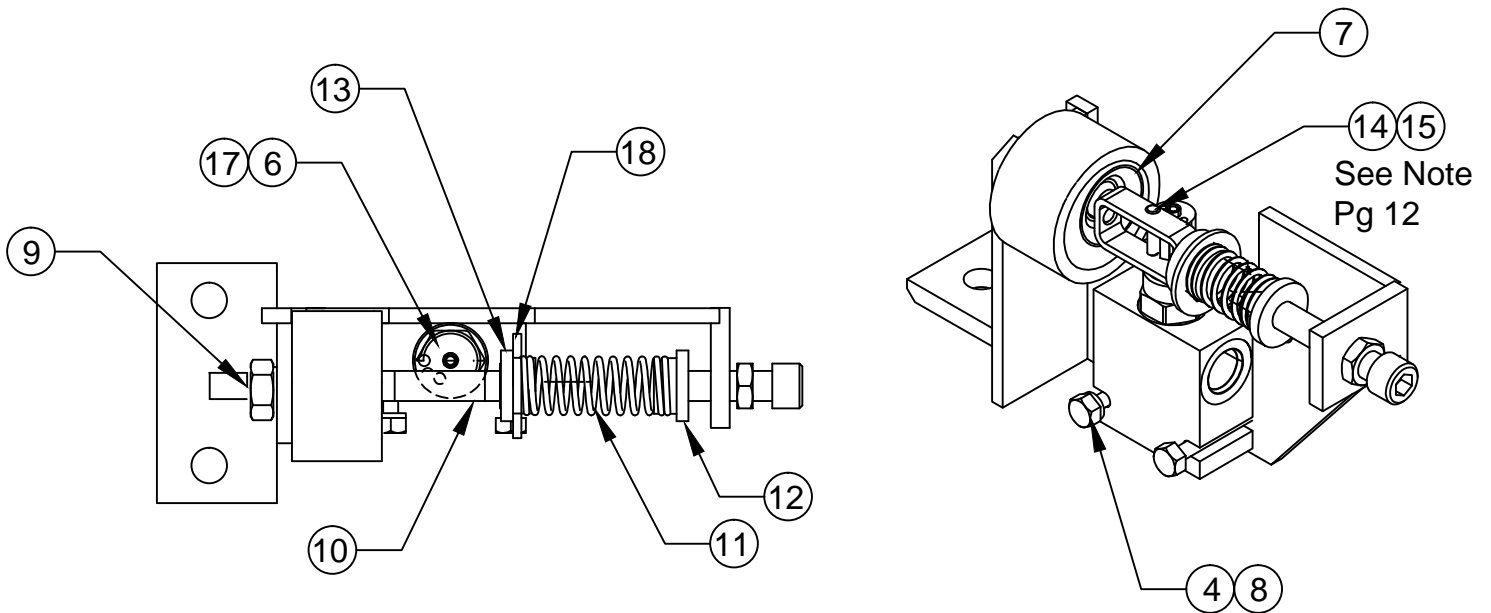

Reference 111289 see floating pads assembly

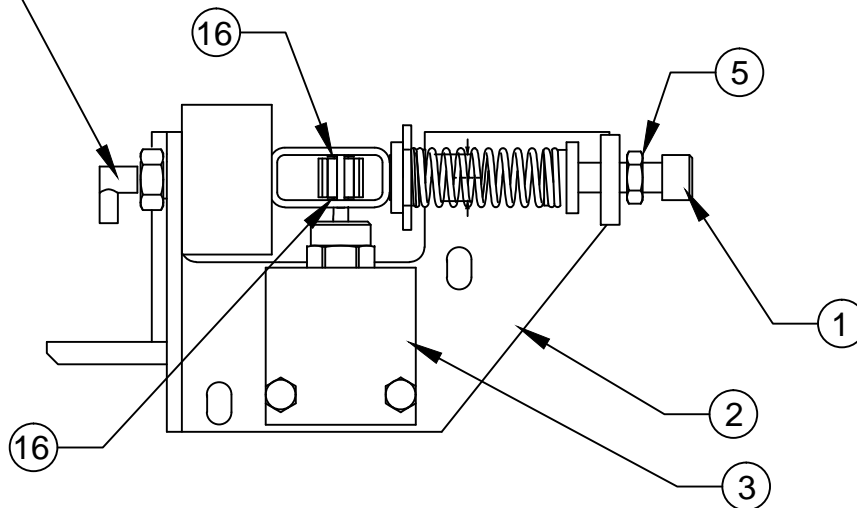

ARM SLIDE & SHIM REPLACEMENT

1. To replace the slides, the arms need to be in the fully open position. Release system pressure prior to removing the arms by turning the truck off and working the side shift and clamp function controls several times.
2. Support the arm with an overhead crane or lift truck. Be sure to secure the chain or sling in a manner that prevents the arm from falling out of the chain or sling when hanging free of the clamp.
3. Remove the cotter pin, slotted nut and spherical bearing from the end of the clamp cylinder rod. Keeping hands and feet clear, and carefully slide the clamp arm off of the clamp frame.
4. Inspect slides and slide buttons for wear. Slides may be rotated end-to-end and reused if excessively worn on the outer end only. Extra shims may be used to tighten operating clearance on slightly worn slides. Replace any slides worn to less than 0.15" (3.8mm) thick or any slide that is deeply scored or broken.

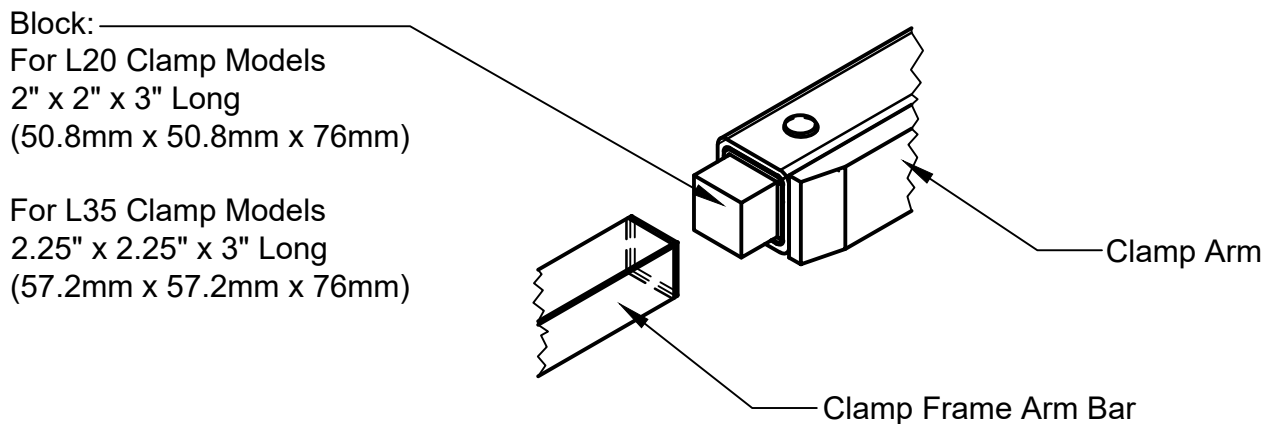

5. To aid in replacing the slides a block may be fashioned of wood or another convenient material to the dimensions shown above. The block is inserted to the end of the arm to hold the slides, shims, and buttons in position while the arm is inserted over the arm bars on the clamp frame. The block is expelled out the opposite end of the arm as the arm is pushed onto the frame. Prior to installing the arm the block may be used to determine the number of shims to place under the slides. Adjust the clearance between the slides and the block to provide approximately .06" (1.5mm) running clearance between the slides and arm when installed.
6. Keeping hands and feet clear, carefully slide the clamp arm onto the clamp frame. Be sure the arm moves freely without excessive binding. If the arm is too loose or too tight add or remove shims as required.
7. Install the spherical bearing, slotted nut and cotter pin onto the end of the clamp cylinder rod. Be sure to leave .03"-.06" (.7mm to 1.5mm) clearance to allow the cylinder to "float" on its mountings.

TROUBLE SHOOTING GUIDE

LOADS SLIPPING OR DROPPING

POSSIBLE CAUSES

1. Clamp force set too low.
2. Internal leakage in cylinder.
3. Load too heavy for the clamp capacity.
4. Load may not be stacked correctly or may need to be unitized.
5. Bent arms or contact pads.
6. Damaged / leaking hydraulic hose

SOLUTION

1. Adjust clamp force.
2. Replace cylinder seals. If tube, pistons or rod is scored replace with new parts.
3. Consult factory.
4. Restack or unitize load (shrink wrap).
5. Consult factory.
6. Replace damaged hose.

CRUSHING LOADS

POSSIBLE CAUSES

1. Clamp force set too high.
2. Bent arms or contact pads.
3. Leak in the bladder system.

SOLUTION

1. Adjust clamp force.
2. Consult factory.
3. Check for leaks and repair.

ARM CHATTERING OR ERRATIC MOVEMENT

POSSIBLE CAUSES

1. Bent clamp arms.
2. Nylon slides sticking.
Note: Sticking slides can cause inconsistent force measurements.
3. Nylon slides worn, broken or missing.

SOLUTION

1. Consult factory.
2. Clean slides if necessary, the slides are self lubricating.
3. Replace damaged slides, shims, and retaining buttons.